

PROJECT: 44856.3.11 TIP: W-5710K

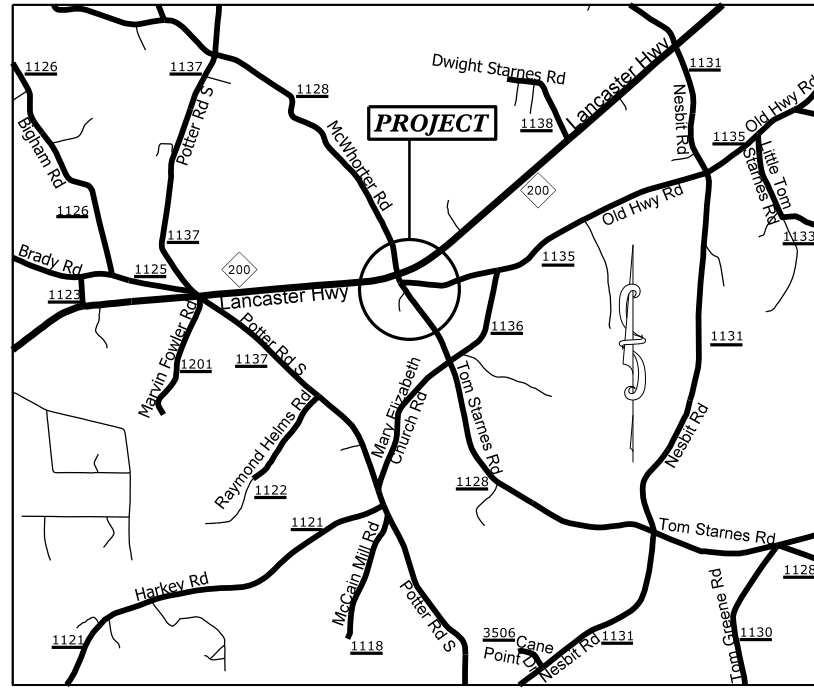

VICINITY MAP NOT TO SCALE

STATE OF NORTH CAROLINA
 DIVISION OF HIGHWAYS
UNION COUNTY

LOCATION: NC 200 AT McWHORTER RD. (SR-1128) AND TOM STARNES RD. (SR-1128)

TYPE OF WORK: GRADING, MILLING, PAVING, MONOLITHIC CONCRETE ISLANDS, DRAINAGE, PAVEMENT REMOVAL
 CONCRETE CURB AND GUTTER, AND THERMOPLASTIC PAVEMENT MARKINGS

STATE	STATE PROJECT REFERENCE NO.	SHEET NO.	TOTAL SHEETS
N.C.	44856.3.11	1	
STATE PROJ. NO.	F.A. PROJ. NO.	DESCRIPTION	
44856.1.11	HSIP-0200(007)	P.E.	
44856.2.11	HSIP-0200(007)	RW	
44856.3.11	HSIP-0200(007)	CONST.	

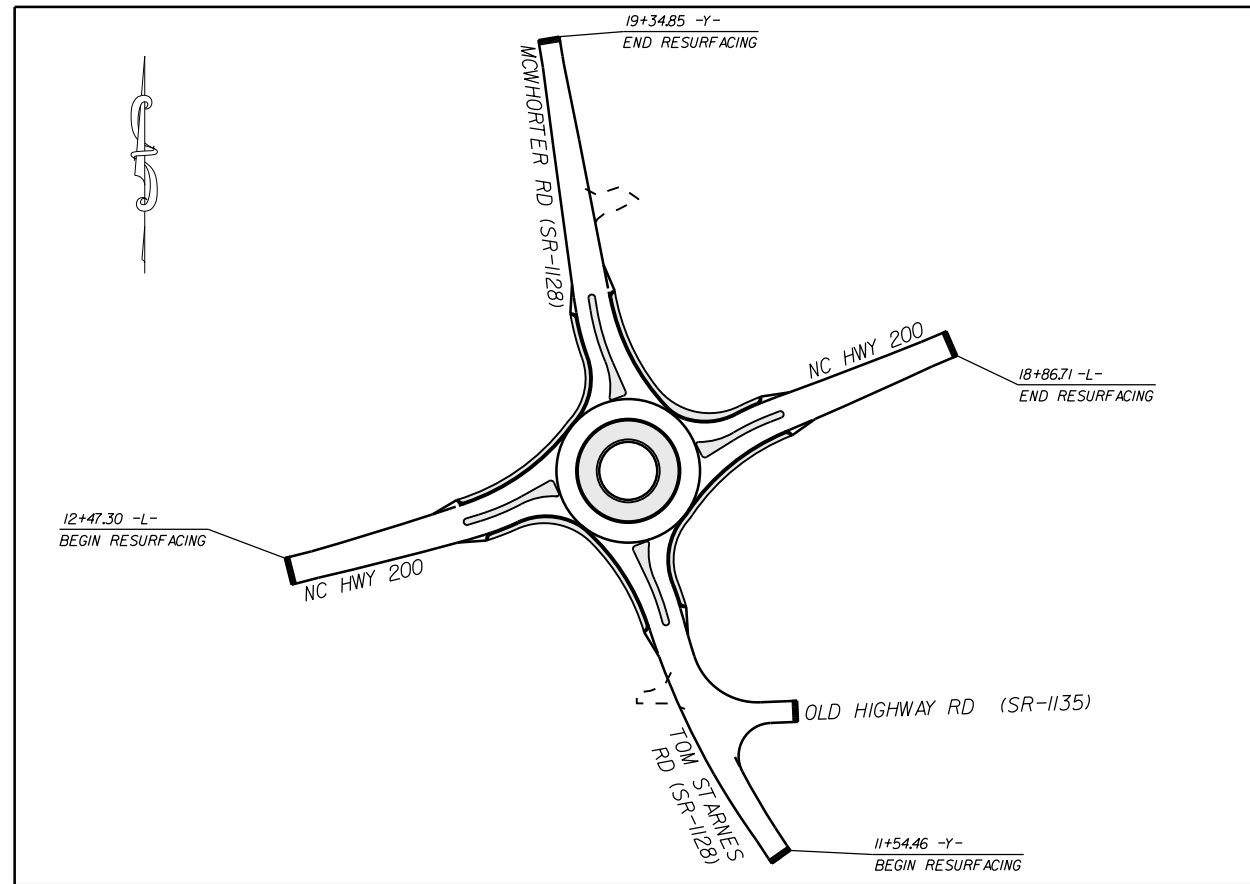

CLEARING ON THIS PROJECT SHALL BE TO THE LIMITS ESTABLISHED BY METHOD III AS DESCRIBED IN THE NCDOT STANDARD DRAWINGS

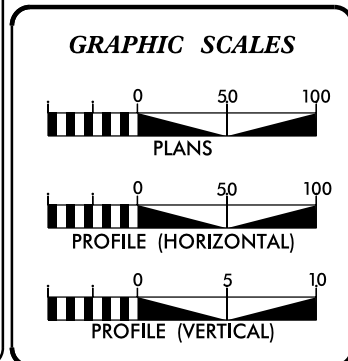

DESIGN DATA

ADT	=	
ADT	=	
DHV	=	%
D	=	%
T	=	%
V	=	MPH

PROJECT LENGTH

LENGTH OF ROADWAY PROJECT	=	0.27 MILES
TOTAL LENGTH OF STATE PROJECT	=	0.27 MILES

Prepared in the Office of:
DIVISION OF HIGHWAYS
 DIVISION TEN
 DIVISION DESIGN / CONSTRUCT UNIT

2018 STANDARD SPECIFICATIONS	
RIGHT OF WAY DATE:	DONALD HARWARD PROJECT ENGINEER
LETTING DATE:	DONALD HARWARD PROJECT DESIGN ENGINEER

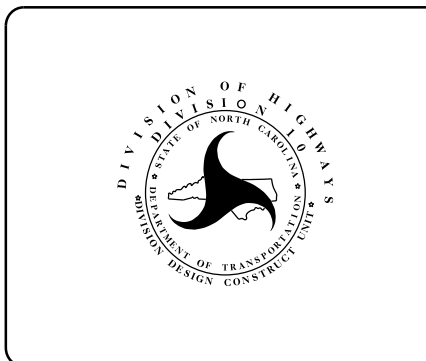

ROADWAY DESIGN ENGINEER

Seal of Michael E. Ferguson, Professional Engineer, Seal 034357.

DocuSigned by: *Michael E. Ferguson*

SIGNATURE: A92E75CC0FFB43B...

SURVEY CONTROL SHEET

PROJECT NO.	SHEET NO.
44856.3.11	1A
F.A. PROJECT NO. HSIP-0200(007)	

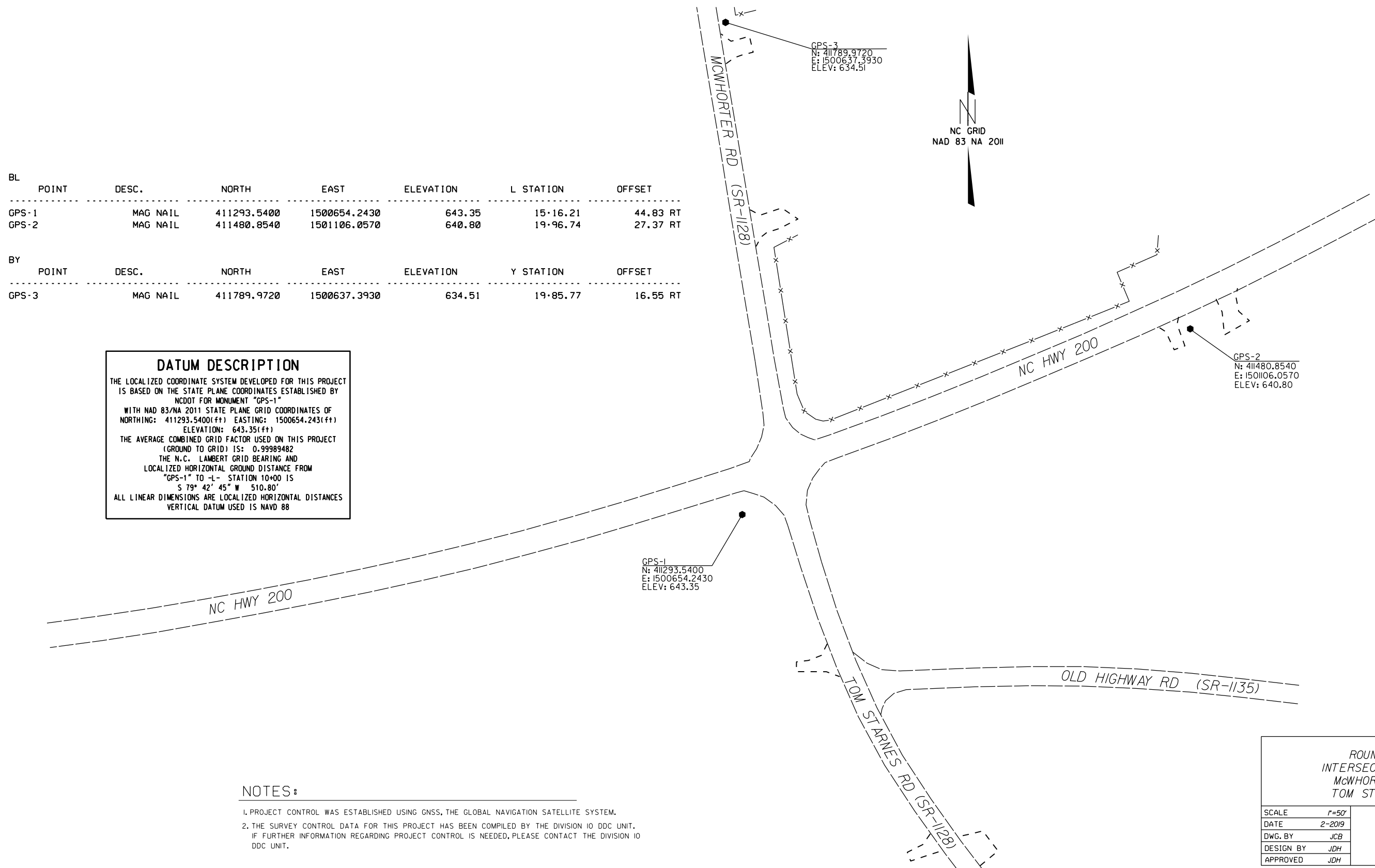

BL	POINT	DESC.	NORTH	EAST	ELEVATION	L STATION	OFFSET
	GPS-1	MAG NAIL	411293.5400	1500654.2430	643.35	15+16.21	44.83 RT
	GPS-2	MAG NAIL	411480.8540	1501106.0570	640.80	19+96.74	27.37 RT

BY	POINT	DESC.	NORTH	EAST	ELEVATION	Y STATION	OFFSET
	GPS-3	MAG NAIL	411789.9720	1500637.3930	634.51	19+85.77	16.55 RT

DATUM DESCRIPTION

THE LOCALIZED COORDINATE SYSTEM DEVELOPED FOR THIS PROJECT IS BASED ON THE STATE PLANE COORDINATES ESTABLISHED BY NCDOT FOR MONUMENT "GPS-1" WITH NAD 83/NA 2011 STATE PLANE GRID COORDINATES OF NORTHING: 411293.5400(ft) EASTING: 1500654.243(ft) ELEVATION: 643.35(ft)

THE AVERAGE COMBINED GRID FACTOR USED ON THIS PROJECT (GROUND TO GRID) IS: 0.99989482

THE N.C. LAMBERT GRID BEARING AND LOCALIZED HORIZONTAL GROUND DISTANCE FROM "GPS-1" TO -L- STATION 10+00 IS
S 79° 42' 45" W 510.80'

ALL LINEAR DIMENSIONS ARE LOCALIZED HORIZONTAL DISTANCES
VERTICAL DATUM USED IS NAVD 88

- NOTES :**
1. PROJECT CONTROL WAS ESTABLISHED USING GNSS, THE GLOBAL NAVIGATION SATELLITE SYSTEM.
 2. THE SURVEY CONTROL DATA FOR THIS PROJECT HAS BEEN COMPILED BY THE DIVISION 10 DDC UNIT. IF FURTHER INFORMATION REGARDING PROJECT CONTROL IS NEEDED, PLEASE CONTACT THE DIVISION 10 DDC UNIT.

ROUNDABOUT AT THE
INTERSECTION OF NC 200 AND
MCWHORTER RD.(SR-1128) /
TOM STARNES RD.(SR-1128)

SCALE	1"=50'		REVISIONS
DATE	2-2019		
DWG. BY	JCB		
DESIGN BY	JDH		
APPROVED	JDH		

RIGHT OF WAY, EASEMENT AND PROPOSED ALIGNMENT SHEET

L

TYPE	STATION	NORTH	EAST
PC	10+00.00	411202.3176	1500151.6569
PCC	14+12.35	411298.7303	1500552.3408
PT	15+05.00	411336.3176	1500636.7599
POT	15+70.00	411345.5775	1500701.0969
PC	16+35.00	411357.6042	1500764.9746
PRC	17+21.71	411397.7171	1500841.6298
PT	20+57.00	411531.4281	1501149.0147

ROW MARKERS IRON PIN & CAP

ALIGN	STATION	OFFSET	NORTH	EAST
L	12+50.00	30.16	411226.0311	1500403.3476
L	13+00.00	-29.85	411296.7240	1500436.5712
L	13+50.00	44.00	411238.8704	1500504.5109
L	14+00.00	48.00	411249.1838	1500554.2524
L	14+50.00	50.00	411265.3024	1500607.0258
L	15+00.00	-44.00	411371.7095	1500610.2001
L	17+00.00	-38.00	411424.0189	1500805.9655
L	17+00.00	50.00	411343.7971	1500842.1381
L	17+50.00	-30.12	411436.0798	1500856.8091
L	18+50.00	29.73	411418.7492	1500972.0467

Y

TYPE	STATION	NORTH	EAST
PC	10+00.00	410872.1134	1500931.6373
PCC	11+66.83	411006.2072	1500832.4133
PRC	13+89.52	411205.9119	1500736.0284
PT	14+70.00	411200.8361	1500706.8892
POT	15+35.00	411345.5775	1500701.0969
PC	16+00.00	411410.5125	1500698.1899
PT	16+98.88	411504.2238	1500667.8106
POT	21+33.00	411932.5400	1500597.0760

ROW MARKERS IRON PIN & CAP

ALIGN	STATION	OFFSET	NORTH	EAST
Y	11+50.00	30.09	411009.7771	1500866.6677
Y	11+70.00	-29.61	410991.9826	1500806.2446
Y	12+25.00	42.00	411076.3236	1500837.4958
Y	12+50.00	-40.00	411058.2673	1500753.7165
Y	13+00.00	-40.00	411105.7577	1500730.5291
Y	13+50.00	-34.00	411156.8235	1500716.4362
Y	13+75.00	-29.85	411182.9021	1500711.9162
Y	14+10.00	-29.93	411215.6686	1500701.4631
Y	14+50.00	50.00	411282.6637	1500761.0797
Y	14+60.00	-44.47	411253.2018	1500670.7695
Y	16+07.00	48.00	411437.3432	1500738.5133
Y	16+50.00	-34.05	411446.3153	1500646.9068
Y	16+50.00	45.00	411470.5644	1500722.1421
Y	17+50.00	41.00	411561.3389	1500699.9336
Y	18+05.00	29.92	411613.7985	1500680.0400

Y1

TYPE	STATION	NORTH	EAST
POT	10+00.00	411124.3808	1500766.0295
PC	11+28.89	411129.5393	1500894.8132
PT	13+65.41	411121.2845	1501130.9736
POT	14+50.00	411112.0055	1501215.0533

ROW MARKERS IRON PIN & CAP

ALIGN	STATION	OFFSET	NORTH	EAST
Y1	10+25.00	-30.00	411155.3573	1500789.8088
Y1	11+30.00	30.00	411099.6067	1500897.1049

PERMANENT UTILITY EASEMENT

ALIGN	STATION	OFFSET	NORTH	EAST
L	16+35.00	59.60	411302.2374	1500787.0331

PERMANENT DRAINAGE EASEMENT

ALIGN	STATION	OFFSET	NORTH	EAST
Y	17+78.61	-30.08	411577.9845	1500625.1452
Y	17+86.47	-44.40	411583.4028	1500609.7288
Y	18+01.42	-30.08	411600.4912	1500621.4254
Y	18+04.00	-34.79	411602.2714	1500616.3604

PERMANENT UTILITY EASEMENT

ALIGN	STATION	OFFSET	NORTH	EAST
Y	14+25.00	68.00	411263.5582	1500788.2793
Y	14+32.00	46.58	411263.1240	1500765.4892
Y	16+17.85	-74.00	411397.2443	1500622.7634
Y	16+33.00	-90.85	411408.4346	1500600.0194
Y	16+36.75	-49.08	411427.3082	1500637.5552
Y	16+52.00	-67.00	411438.4985	1500614.8111

I, Barry D. Davis, a Professional Land Surveyor in the state of North Carolina hereby certify to the best of my knowledge and belief that the following work item, R/W and Easement Staking, was performed under my responsible charge meeting NCDOT Survey Standards as directed in the NCDOT Location & Surveys guidelines and procedures as of 2017. Those standards can be found at <https://connect.ncdot.gov/resources/Location/Pages/>.

I further certify that the right of way and permanent easement points shown herein and outlined in the tables shown hereon (localized coordinates, station/offset) have been checked and are accurate representations of the right of way and permanent easement points depicted on the corresponding highway plans. I also certify that the right of way and permanent easement points shown herein have been field monumented under my supervision from survey control established under my supervision; that the depicted property data shown herein were surveyed under my supervision; and these monuments denote the right of way and easement boundaries at the time of staking which may be subject to change due to right of way revisions (see deeds for final determination).

Witness my signature, registration number and seal this 11th day of April 2019

Barry D. Davis, Professional Land Surveyor
 DocuSigned by: Barry Davis PLS# L-4384
 0E2AAE4F48174DC...



NOTES:

- PROJECT CONTROL WAS ESTABLISHED USING GNSS, THE GLOBAL NAVIGATION SATELLITE SYSTEM.
- THE SURVEY CONTROL DATA FOR THIS PROJECT HAS BEEN COMPILED BY THE DIVISION IO DDC UNIT. IF FURTHER INFORMATION REGARDING PROJECT CONTROL IS NEEDED, PLEASE CONTACT THE DIVISION IO DDC UNIT.

ROUNDABOUT AT THE
INTERSECTION OF NC 200 AND
McWHORTER RD.(SR-1128)/
TOM STARNES RD.(SR-1128)

SCALE	N/A		REVISIONS
DATE	2-2019		
DWG. BY	JCB		
DESIGN BY	JDH		
APPROVED	JDH		



20

PC Sta. 10+00.00 -L-

PI Sta 12+06.40 -L-
 $\Delta = 6^{\circ} 35' 44.5" (LT)$
 $D = 1^{\circ} 35' 58.4"$
 $L = 412.35'$
 $T = 206.40'$
 $R = 3,582.00'$

CYNTHIA A. HAHN
 AND HUSBAND
 MARK VAN KUREN
 DB 3509 PG 426

PI Sta 14+58.92 -L-
 $\Delta = 14^{\circ} 20' 50.2" (LT)$
 $D = 15^{\circ} 29' 07.2"$
 $L = 92.65'$
 $T = 46.57'$
 $R = 370.00'$

PT Sta. 15+05.00 -L-
 PI Sta. 15+35.00 -Y-

16+50 -Y-
 34.05'LT
 16+39.34
 46'LT
 16+36.75 -Y-
 49.08'LT
 16+52 -Y-
 67'LT
 16+33 -Y-
 90.85'LT
 16+17.85 -Y-
 74'LT
 15+00 -L-
 44'LT

CYNTHIA A. HAHN
 AND HUSBAND
 MARK VAN KUREN
 DB 3509 PG 426

PI Sta 14+29.85 -Y-
 $\Delta = 9^{\circ} 13' 19.5" (LT)$
 $D = 1^{\circ} 27' 33.0"$
 $L = 80.48'$
 $T = 40.33'$
 $R = 500.00'$

KEVIN CLARK GODBOLD
 DB 122 PG 548

PI Sta 12+79.13 -Y-
 $\Delta = 18^{\circ} 14' 44.6" (RT)$
 $D = 8^{\circ} 11' 36.3"$
 $L = 222.69'$
 $T = 112.29'$
 $R = 699.29'$

PI Sta 10+83.44 -Y-
 $\Delta = 3^{\circ} 13' 36.5" (RT)$
 $D = 1^{\circ} 56' 02.9"$
 $L = 166.83'$
 $T = 83.44'$
 $R = 2,962.34'$

GPS-3

18+30
 29.92'RT
 18+05 -Y-
 29.92'RT
 17+50 -Y-
 41'RT
 17+50
 46'RT

PI Sta 16+49.81 -Y-
 $\Delta = 17^{\circ} 10' 05.7" (RT)$
 $D = 17^{\circ} 21' 44.5"$
 $L = 98.88'$
 $T = 49.81'$
 $R = 330.00'$

PI Sta 18+89.44 -L-
 $\Delta = 4^{\circ} 21' 29.2" (LT)$
 $D = 1^{\circ} 17' 59.3"$
 $L = 335.29'$
 $T = 167.73'$
 $R = 4,408.02'$

ANNE D. KING
 DB 380 PG 429

1

CHRISTOPHER R. MAUNEY
 DB 690 PG 166

I, Barry D. Davis, a Professional Land Surveyor in the state of North Carolina hereby certify to the best of my knowledge and belief that the following work item, R/W and Easement Staking, was performed under my responsible charge meeting NCDOT Survey Standards as directed in the NCDOT Location & Surveys guidelines and procedures as of 2017. Those standards can be found at <https://connect.ncdot.gov/resources/Location/Pages/>.

I further certify that the right of way and permanent easement points shown herein and outlined in the tables shown hereon (localized coordinates, station/offset) have been checked and are accurate representations of the right of way and permanent easement points depicted on the corresponding highway plans. I also certify that the right of way and permanent easement points shown herein have been field monumented under my supervision from survey control established under my supervision; that the depicted property data shown herein were surveyed under my supervision; and these monuments denote the right of way and easement boundaries at the time of staking which may be subject to change due to right of way revisions (see deeds for final determination).

Witness my signature, registration number and seal this 11th day of April 2019

Barry D. Davis, Professional Land Surveyor PLS# L-4384

DocuSigned by:
 Barry Davis
 0E2AAE4F48174DC...



GPS-2

LARRY S. CARTER
 AND WIFE
 VICKIE SUE CARTER
 DB 892 PG 309

2

CYNTHIA A. HAHN
 AND HUSBAND
 MARK VAN KUREN
 DB 3509 PG 426

PI Sta 16+78.56 -L-
 $\Delta = 13^{\circ} 25' 41.0" (RT)$
 $D = 15^{\circ} 29' 07.2"$
 $L = 86.71'$
 $T = 43.56'$
 $R = 370.00'$

JOEL ELDON CLARK
 DB ??? PG ???

3

PI Sta 12+47.37 -YI-
 $\Delta = 8^{\circ} 35' 29.2" (RT)$
 $D = 3^{\circ} 37' 56.4"$
 $L = 236.53'$
 $T = 118.49'$
 $R = 1,577.38'$

ROUNDABOUT AT THE
 INTERSECTION OF NC 200 AND
 McWHORTER RD.(SR-1128) /
 TOM STARNES RD.(SR-1128)

SCALE	1"=50'		REVISIONS
DATE	2-2019		
DWG. BY	JCB		
DESIGN BY	JDH		
APPROVED	JDH		

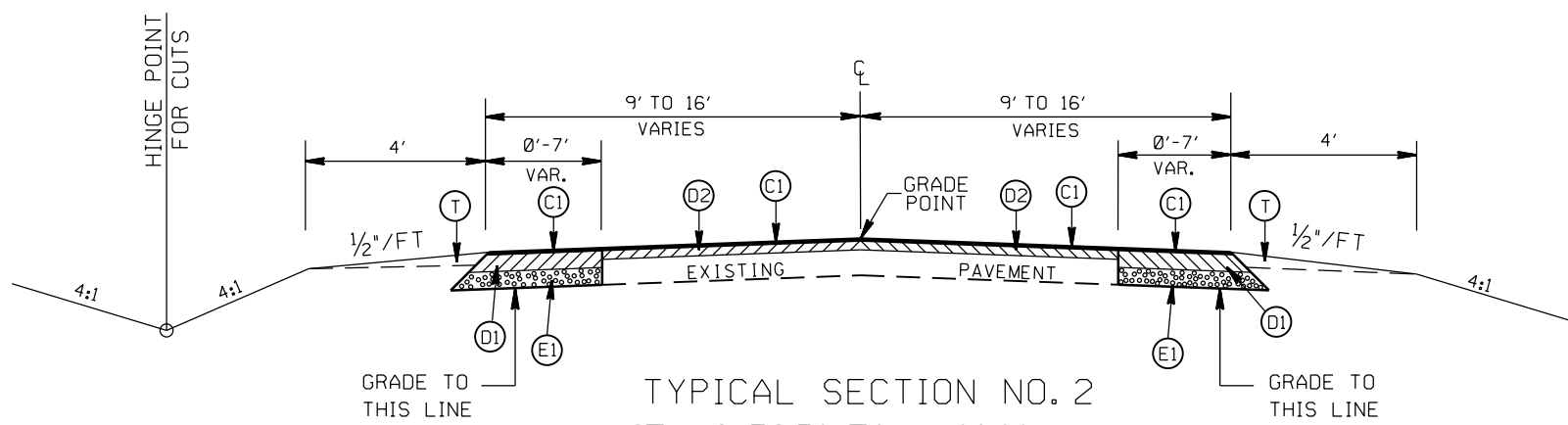
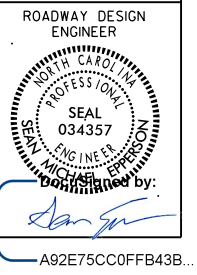

TYPICAL SECTION NO. 2
 STA. 12+72.30 TO 14+00.00 -L-
 STA. 18+00.00 TO 18+61.71 -L-
 STA. 11+79.46 TO 13+50.00 -Y-
 STA. 17+00.00 TO 19+09.85 -Y-
 STA. 10+50.00 TO 10+54.97 -YI-

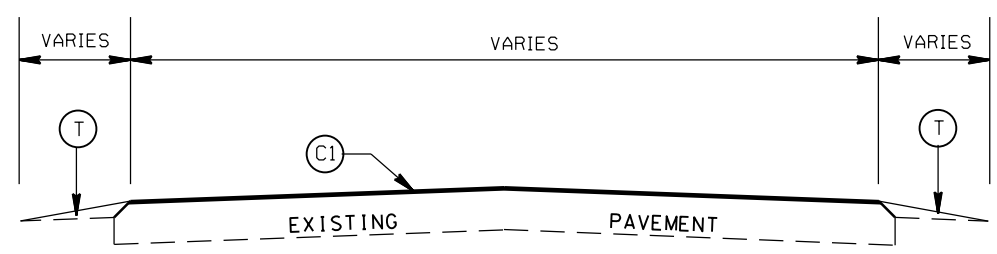

TYPICAL SECTION NO. 1
 STA 12+47.30 TO 12+72.30 -L-
 STA 18+61.71 TO 18+86.71 -L-
 STA 11+54.46 TO 11+79.46 -Y-
 STA 19+09.85 TO 19+34.85 -Y-
 STA 10+63.41 TO 10+88.41 -YI-

PAVEMENT SCHEDULE

(C1)	PROP. APPROX. 1½" ASPHALT CONC. SURFACE COURSE, TYPE S9.5C, AT AN AVERAGE RATE OF 168 LBS. PER SQ. YD.
(C2)	PROP. APPROX. 3" ASPHALT CONC. SURFACE COURSE, TYPE S9.5C, AT AN AVERAGE RATE OF 168 LBS. PER SQ. YD. IN EACH OF TWO LAYERS.
(D1)	PROP. APPROX. 4" ASPHALT CONC. INTERMEDIATE COURSE, TYPE I19.0C, AT AN AVERAGE RATE OF 456 LBS. PER SQ. YD.
(D2)	PROP. VARIABLE DEPTH ASPHALT CONC. INTERMEDIATE COURSE.
(E1)	PROP. APPROX. 5" ASPHALT CONC. BASE COURSE, TYPE B25.0C, AT AN AVERAGE RATE OF 570 LBS. PER SQ. YD.
(R1)	PROP. 2'-6" CONC. CURB & GUTTER
(R2)	PROP. 1'-6" CONC. CURB & GUTTER, CLASS AA CONCRETE
(R3)	PROP. 7" TRUCK MOUNTABLE CONC. ISLAND, CLASS AA CONCRETE
(R4)	PROP. 5" MONOLITHIC CONC. ISLAND (SURFACE MOUNTED)
(R5)	PROP. 1'-6" CURB & GUTTER W/ BLACK TINT, CLASS AA CONCRETE
(R6)	PROP. 7" TRUCK MOUNTABLE CONC. ISLAND W/ BLACK TINT, CLASS AA CONCRETE
(T)	EARTH MATERIAL

ROUNDABOUT AT THE
 INTERSECTION OF NC 200 AND
 McWHORTER RD.(SR-1128)/
 TOM STARNES RD.(SR-1128)

SCALE	N/A		REVISIONS
DATE	2-2019		
DWG. BY	JCB		
DESIGN BY	JDH		
APPROVED	JDH		

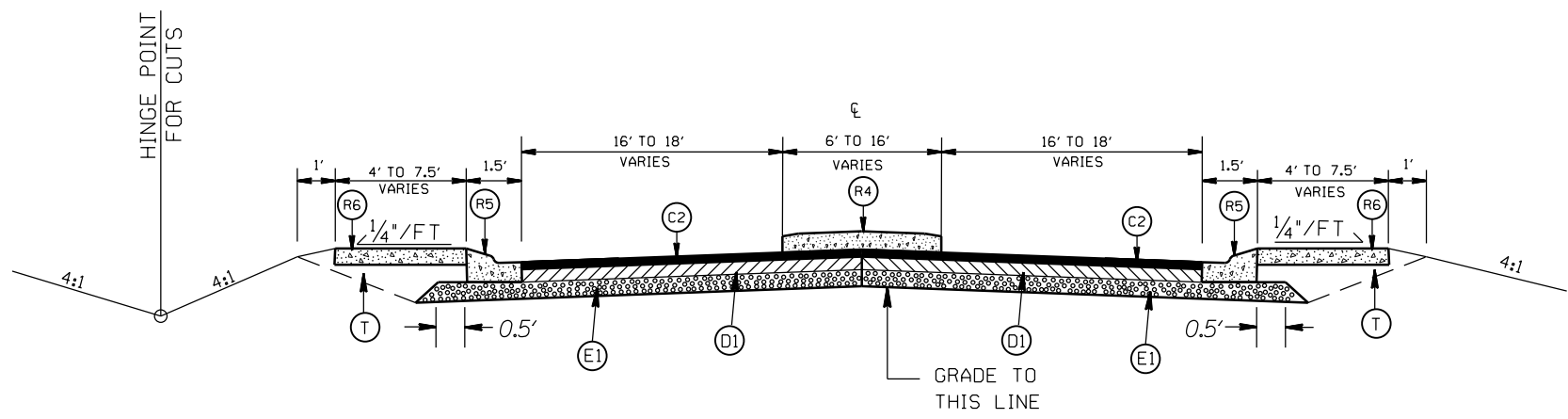
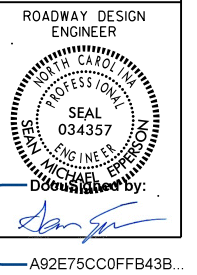

TYPICAL SECTION NO. 4
 STA. 14+12.35 TO 15+05.00 -L-
 STA. 16+35.00 TO 17+21.71 -L-
 STA. 13+89.52 TO 14+70.00 -Y-
 STA. 16+00.00 TO 16+99.85 -Y-

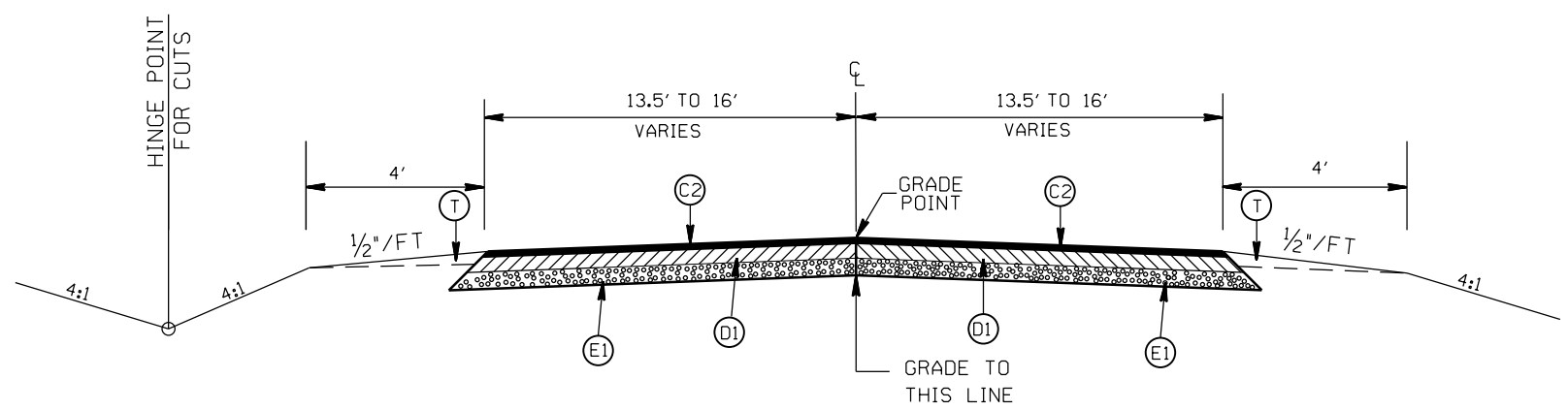

TYPICAL SECTION NO. 3
 STA. 14+00.00 TO 14+12.35 -L-
 STA. 17+21.71 TO 18+00.00 -L-
 STA. 13+50.00 TO 13+89.52 -Y-
 STA. 16+99.85 TO 17+00.00 -Y-

PAVEMENT SCHEDULE

(C1)	PROP. APPROX. 1 1/2" ASPHALT CONC. SURFACE COURSE, TYPE S9.5C, AT AN AVERAGE RATE OF 168 LBS. PER SQ. YD.
(C2)	PROP. APPROX. 3" ASPHALT CONC. SURFACE COURSE, TYPE S9.5C, AT AN AVERAGE RATE OF 168 LBS. PER SQ. YD. IN EACH OF TWO LAYERS.
(D1)	PROP. APPROX. 4" ASPHALT CONC. INTERMEDIATE COURSE, TYPE I19.0C, AT AN AVERAGE RATE OF 456 LBS. PER SQ. YD.
(D2)	PROP. VARIABLE DEPTH ASPHALT CONC. INTERMEDIATE COURSE.
(E1)	PROP. APPROX. 5" ASPHALT CONC. BASE COURSE, TYPE B25.0C, AT AN AVERAGE RATE OF 570 LBS. PER SQ. YD.
(R1)	PROP. 2'-6" CONC. CURB & GUTTER
(R2)	PROP. 1'-6" CONC. CURB & GUTTER, CLASS AA CONCRETE
(R3)	PROP. 7" TRUCK MOUNTABLE CONC. ISLAND, CLASS AA CONCRETE
(R4)	PROP. 5" MONOLITHIC CONC. ISLAND (SURFACE MOUNTED)
(R5)	PROP. 1'-6" CURB & GUTTER W/ BLACK TINT, CLASS AA CONCRETE
(R6)	PROP. 7" TRUCK MOUNTABLE CONC. ISLAND W/ BLACK TINT, CLASS AA CONCRETE
(T)	EARTH MATERIAL

ROUNDABOUT AT THE
 INTERSECTION OF NC 200 AND
 McWHORTER RD.(SR-1128)/
 TOM STARNES RD.(SR-1128)

SCALE	N/A		REVISIONS
DATE	2-2019		
DWG. BY	JCB		
DESIGN BY	JDH		
APPROVED	JDH		

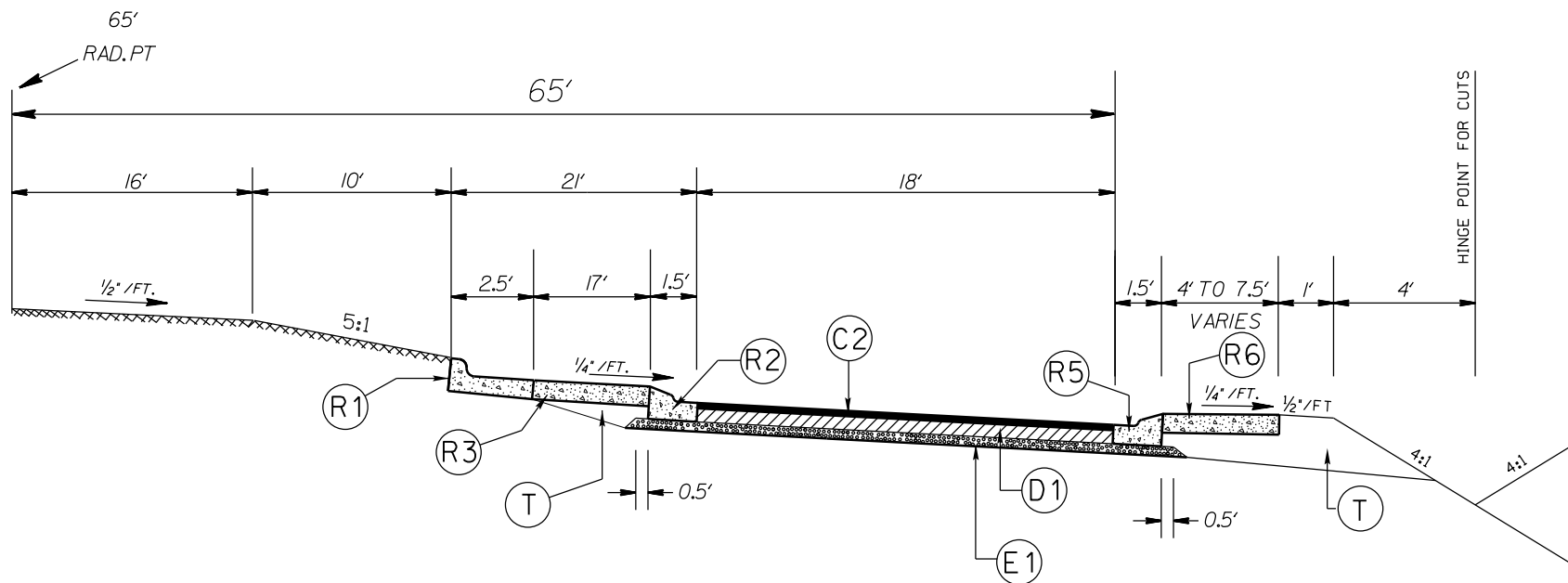
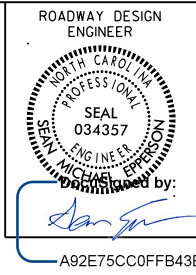

TYPICAL SECTION NO. 6
 ROUNDABOUT
 STA. 15+05.00 TO 16+35.00 -L-
 STA. 14+70.00 TO 16+00.00 -Y-

PAVEMENT SCHEDULE

(C1)	PROP. APPROX. 1 1/2" ASPHALT CONC. SURFACE COURSE, TYPE S9.5C, AT AN AVERAGE RATE OF 168 LBS. PER SQ. YD.
(C2)	PROP. APPROX. 3" ASPHALT CONC. SURFACE COURSE, TYPE S9.5C, AT AN AVERAGE RATE OF 168 LBS. PER SQ. YD. IN EACH OF TWO LAYERS.
(D1)	PROP. APPROX. 4" ASPHALT CONC. INTERMEDIATE COURSE, TYPE I19.0C, AT AN AVERAGE RATE OF 456 LBS. PER SQ. YD.
(D2)	PROP. VARIABLE DEPTH ASPHALT CONC. INTERMEDIATE COURSE.
(E1)	PROP. APPROX. 5" ASPHALT CONC. BASE COURSE, TYPE B25.0C, AT AN AVERAGE RATE OF 570 LBS. PER SQ. YD.
(R1)	PROP. 2'-6" CONC. CURB & GUTTER
(R2)	PROP. 1'-6" CONC. CURB & GUTTER, CLASS AA CONCRETE
(R3)	PROP. 7" TRUCK MOUNTABLE CONC. ISLAND, CLASS AA CONCRETE
(R4)	PROP. 5" MONOLITHIC CONC. ISLAND (SURFACE MOUNTED)
(R5)	PROP. 1'-6" CURB & GUTTER W/ BLACK TINT, CLASS AA CONCRETE
(R6)	PROP. 7" TRUCK MOUNTABLE CONC. ISLAND W/ BLACK TINT, CLASS AA CONCRETE
(T)	EARTH MATERIAL

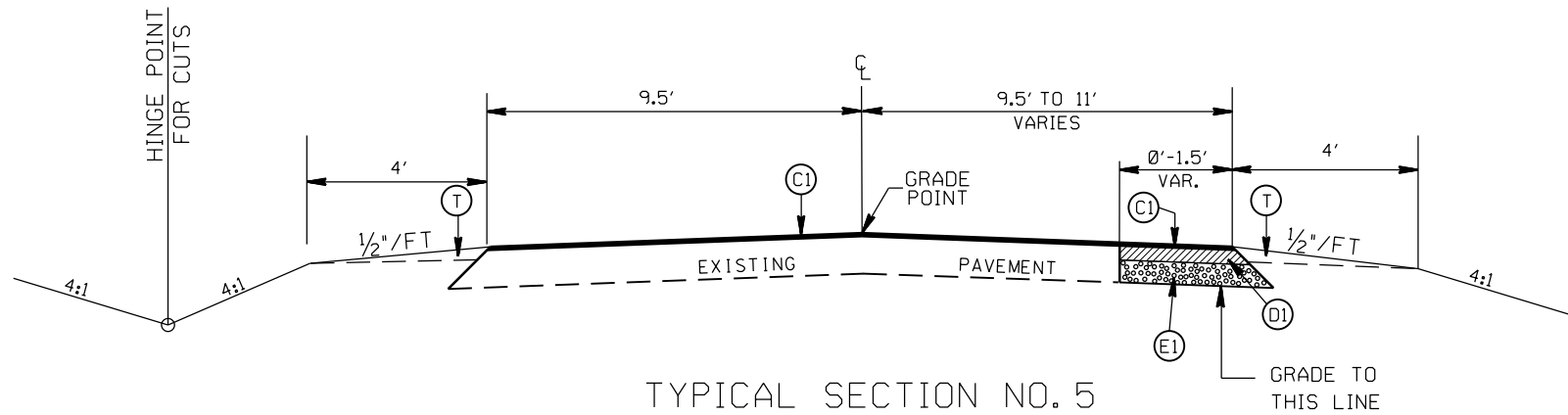

TYPICAL SECTION NO. 5
 STA. 10+54.97 TO 10+63.41 -YI-

ROUNDABOUT AT THE
 INTERSECTION OF NC 200 AND
 McWHORTER RD. (SR-1128) /
 TOM STARNES RD. (SR-1128)

SCALE	N/A		REVISIONS
DATE	2-2019		
DWG. BY	JCB		
DESIGN BY	JDH		
APPROVED	JDH		

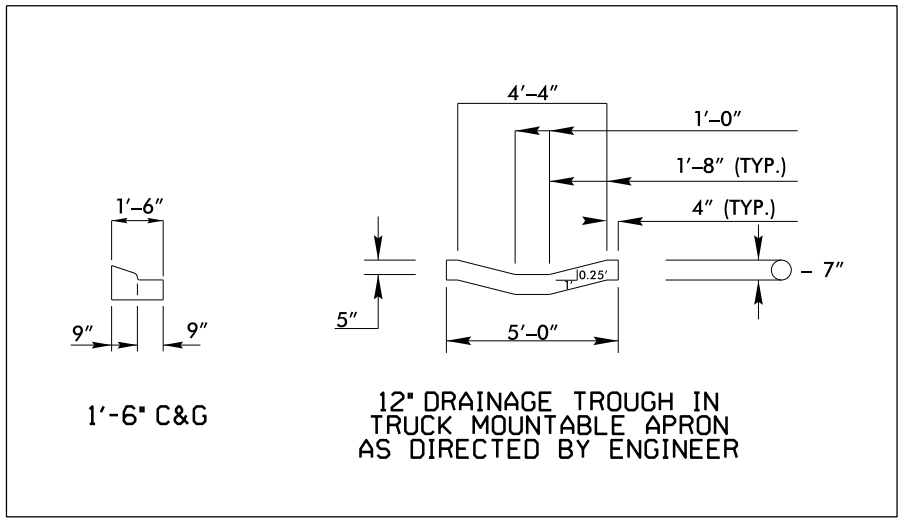
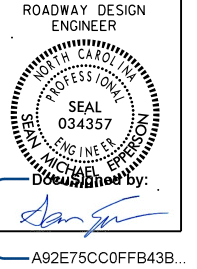

DRAINAGE TROUGH DETAIL

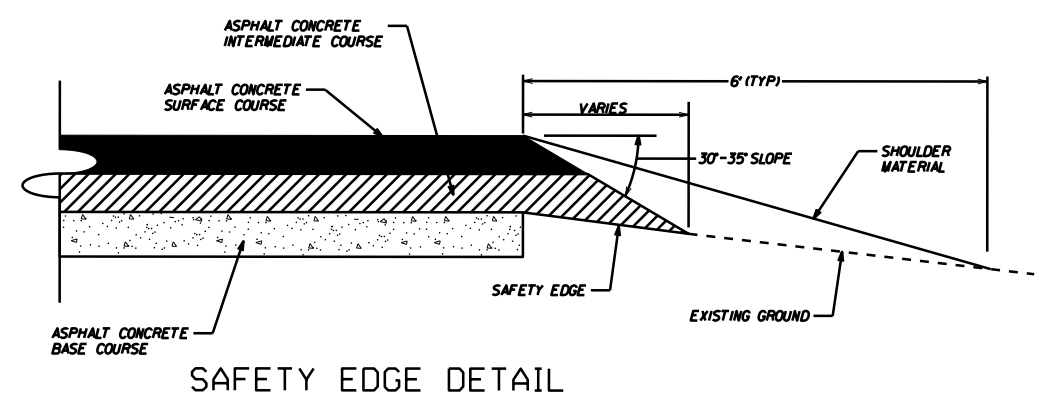

SAFETY EDGE DETAIL

PAVEMENT SCHEDULE

(C1)	PROP. APPROX. 1½" ASPHALT CONC. SURFACE COURSE, TYPE S9.5C, AT AN AVERAGE RATE OF 168 LBS. PER SQ. YD.
(C2)	PROP. APPROX. 3" ASPHALT CONC. SURFACE COURSE, TYPE S9.5C, AT AN AVERAGE RATE OF 168 LBS. PER SQ. YD. IN EACH OF TWO LAYERS.
(D1)	PROP. APPROX. 4" ASPHALT CONC. INTERMEDIATE COURSE, TYPE I19.0C, AT AN AVERAGE RATE OF 456 LBS. PER SQ. YD.
(D2)	PROP. VARIABLE DEPTH ASPHALT CONC. INTERMEDIATE COURSE.
(E1)	PROP. APPROX. 5" ASPHALT CONC. BASE COURSE, TYPE B25.0C, AT AN AVERAGE RATE OF 570 LBS. PER SQ. YD.
(R1)	PROP. 2'-6" CONC. CURB & GUTTER
(R2)	PROP. 1'-6" CONC. CURB & GUTTER, CLASS AA CONCRETE
(R3)	PROP. 7" TRUCK MOUNTABLE CONC. ISLAND, CLASS AA CONCRETE
(R4)	PROP. 5" MONOLITHIC CONC. ISLAND (SURFACE MOUNTED)
(R5)	PROP. 1'-6" CURB & GUTTER W/ BLACK TINT, CLASS AA CONCRETE
(R6)	PROP. 7" TRUCK MOUNTABLE CONC. ISLAND W/ BLACK TINT, CLASS AA CONCRETE
(T)	EARTH MATERIAL

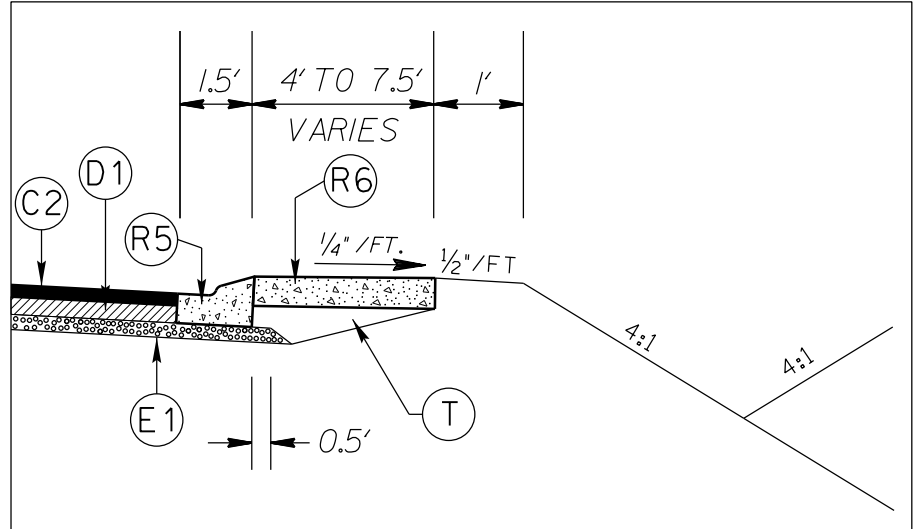

APRON DETAIL

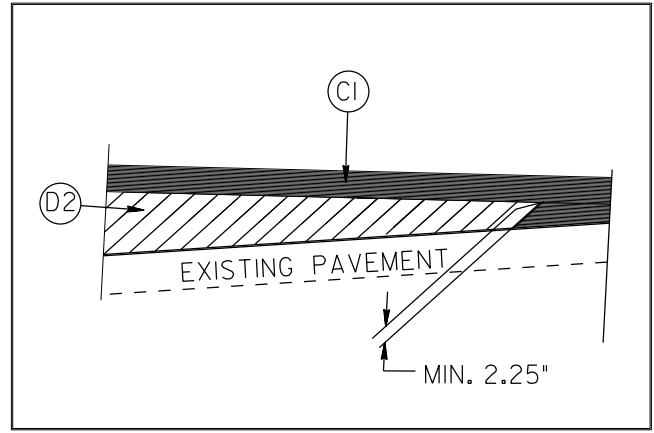

WEDGING DETAIL

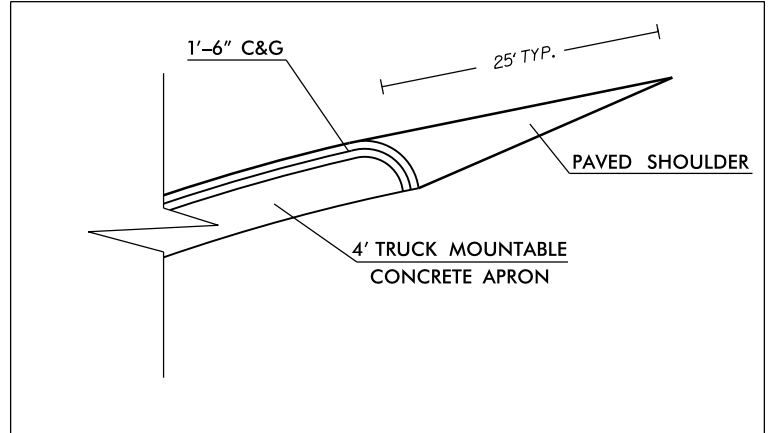

CURB DETAIL

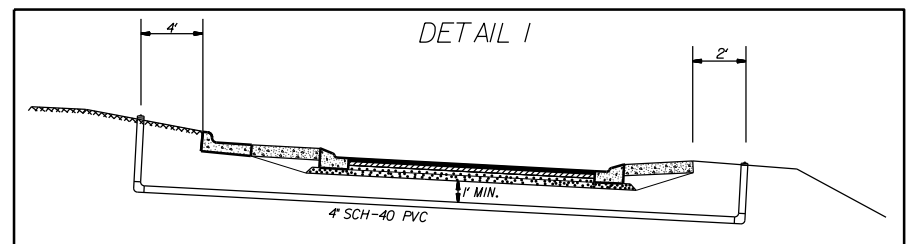

PVC PIPE DETAIL

ROUNDABOUT AT THE INTERSECTION OF NC 200 AND McWHORTER RD.(SR-1128)/ TOM STARNES RD.(SR-1128)

SCALE	r=50'		REVISIONS
DATE	2-2019		
DWG. BY	JCB		
DESIGN BY	JDH		
APPROVED	JDH		

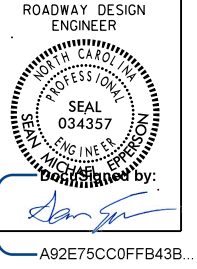

A92E75CC0FFB43B

12" DIA. HOLE LOCATION FOR SIGN U-CHANNEL POST IN SPLITTER ISLANDS

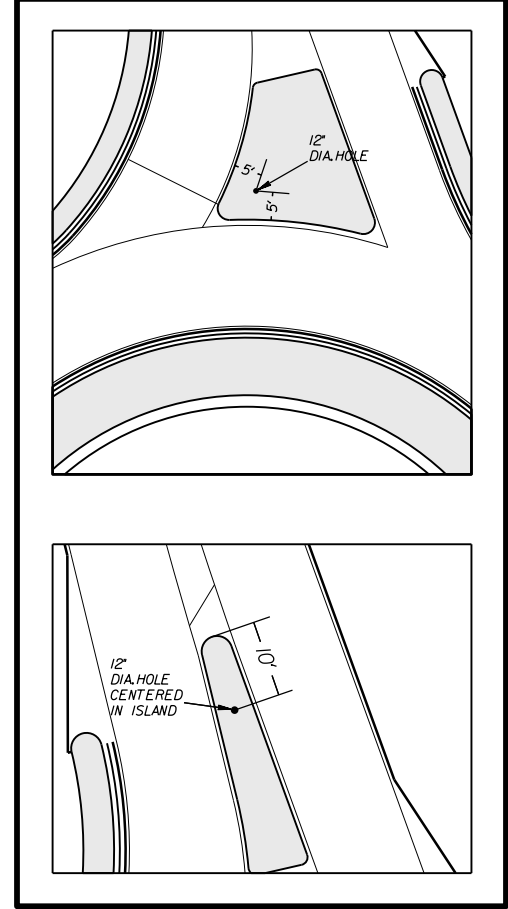

SCALE		N/A		REVISIONS
DATE		2-2019		
DWG. BY		JCB		
DESIGN BY		JDH		
APPROVED		JDH		

ROUNDABOUT AT THE INTERSECTION OF NC 200 AND McWHORTER RD.(SR-1128)/ TOM STARNES RD.(SR-1128)

STATE OF NORTH CAROLINA
DEPT. OF TRANSPORTATION
DIVISION OF HIGHWAYS
RALEIGH, N.C.

ENGLISH STANDARD DRAWING FOR
MOUNTING OF TYPE 'D', 'E', AND 'F' SIGNS ON 'U' CHANNEL POSTS

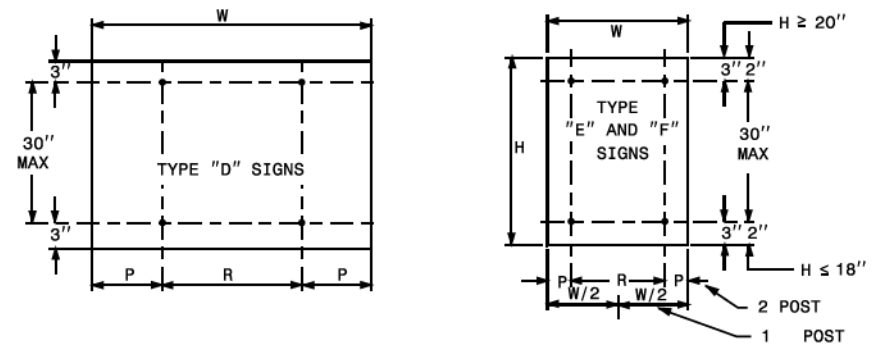
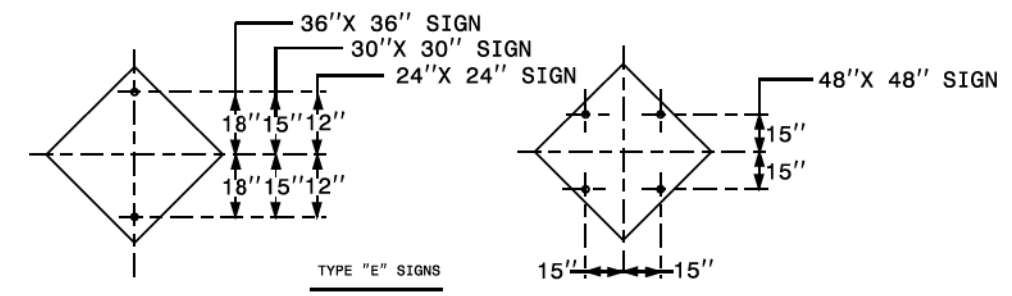
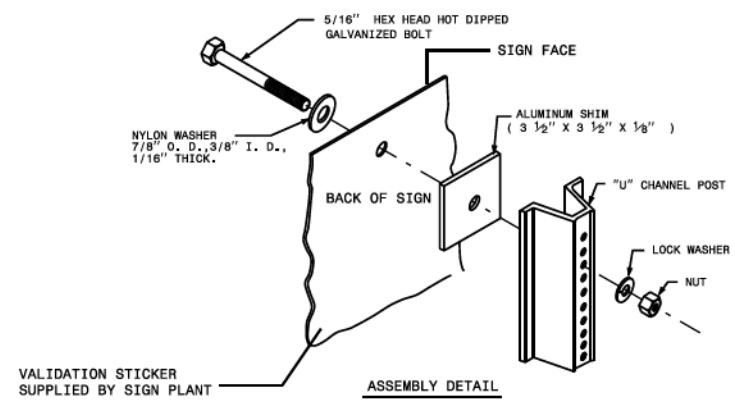

	NO. SUPPORTS		
	2	3 *	4
P	.207W	.145W	.107W
R	.586W	.355W	.262W

UNITS ON ATTACHED SHEET
* MINIMUM 4 FT. BETWEEN CHANNEL POSTS

HOLE PUNCHING DETAIL

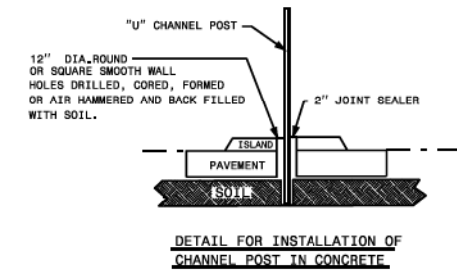

STATE OF NORTH CAROLINA
DEPT. OF TRANSPORTATION
DIVISION OF HIGHWAYS
RALEIGH, N.C.

ENGLISH STANDARD DRAWING FOR
MOUNTING OF TYPE 'D', 'E', AND 'F' SIGNS ON 'U' CHANNEL POSTS

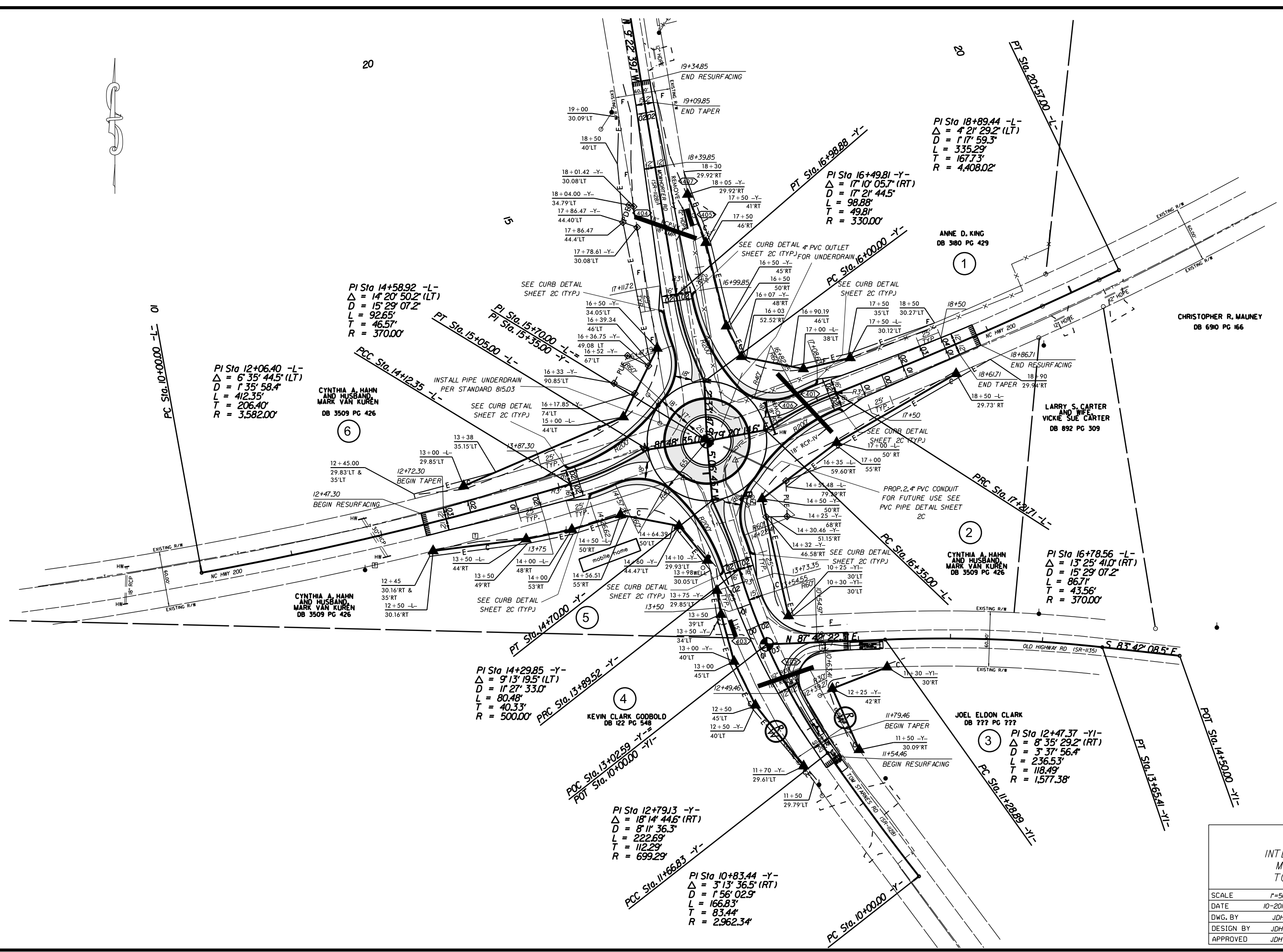
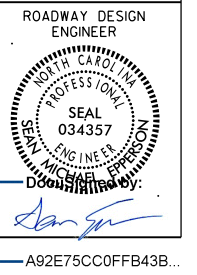

NOTE: INCIDENTAL MILL APPROXIMATELY 25' AT EACH TIE IN TO PROVIDE A SMOOTH TRANSITION TO THE EXISTING ASPHALT PAVEMENT.

ROUNDABOUT AT THE INTERSECTION OF NC 200 AND McWHORTER RD.(SR-1128) / TOM STARNES RD.(SR-1128)

SCALE	1"=50'		REVISIONS
DATE	10-2018		
DWG. BY	JDH		
DESIGN BY	JDH		
APPROVED	JDH		

PROJECT NO.	SHEET NO.
44856.3.II	4A
F.A. PROJECT NO. HSIP-0200(007)	

ROADWAY DESIGN
ENGINEER

Downloaded by:
[Signature]

A92E75CC0FFB43B...

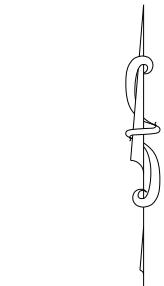
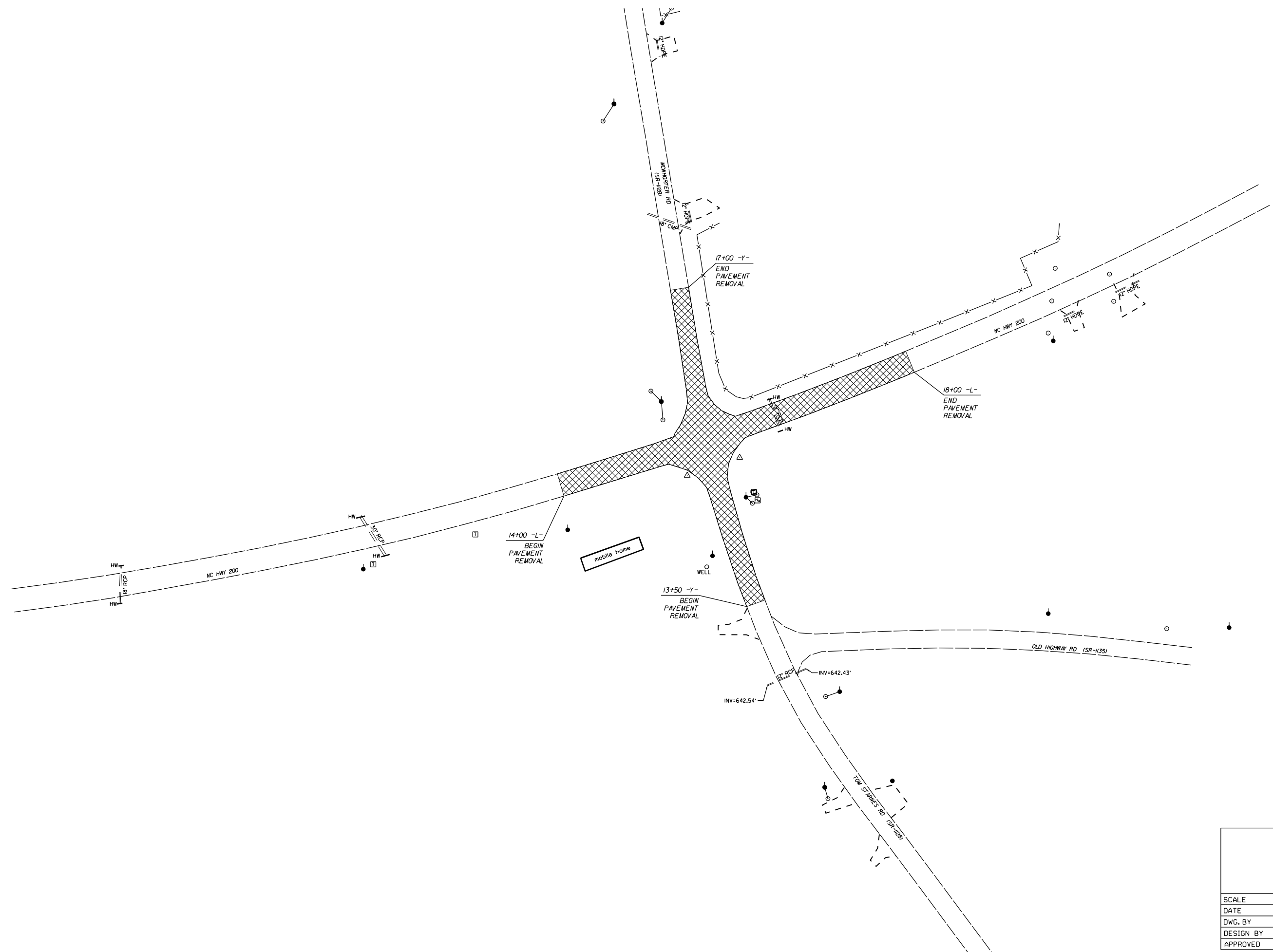



PAVEMENT REMOVAL

ROUNDABOUT AT THE
INTERSECTION OF NC 200 AND
MCWHORTER RD.(SR-1128) /
TOM STARNES RD.(SR-1128)

SCALE	1"=50'		REVISIONS
DATE	1-2019		
DWG. BY	TBL		
DESIGN BY	JDH		
APPROVED	JDH		

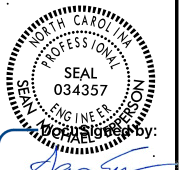
5/14/99
15-MAR-2019 10:25
S:\DC\RDY\Uncon\W-5710K_NC 200.McWhorter_Tom Stornes\W-5710K_NC 200.McWhorter_Tom Stornes.unl.plt.dgn
c:\windows\font\arial.ttf

PROJECT REFERENCE NO. 44856.311	SHEET NO. 5
ROADWAY DESIGN ENGINEER	HYDRAULICS ENGINEER
	
By: 	
DOCUMENT NOT CONSIDERED FINAL UNLESS ALL SIGNATURES COMPLETED	

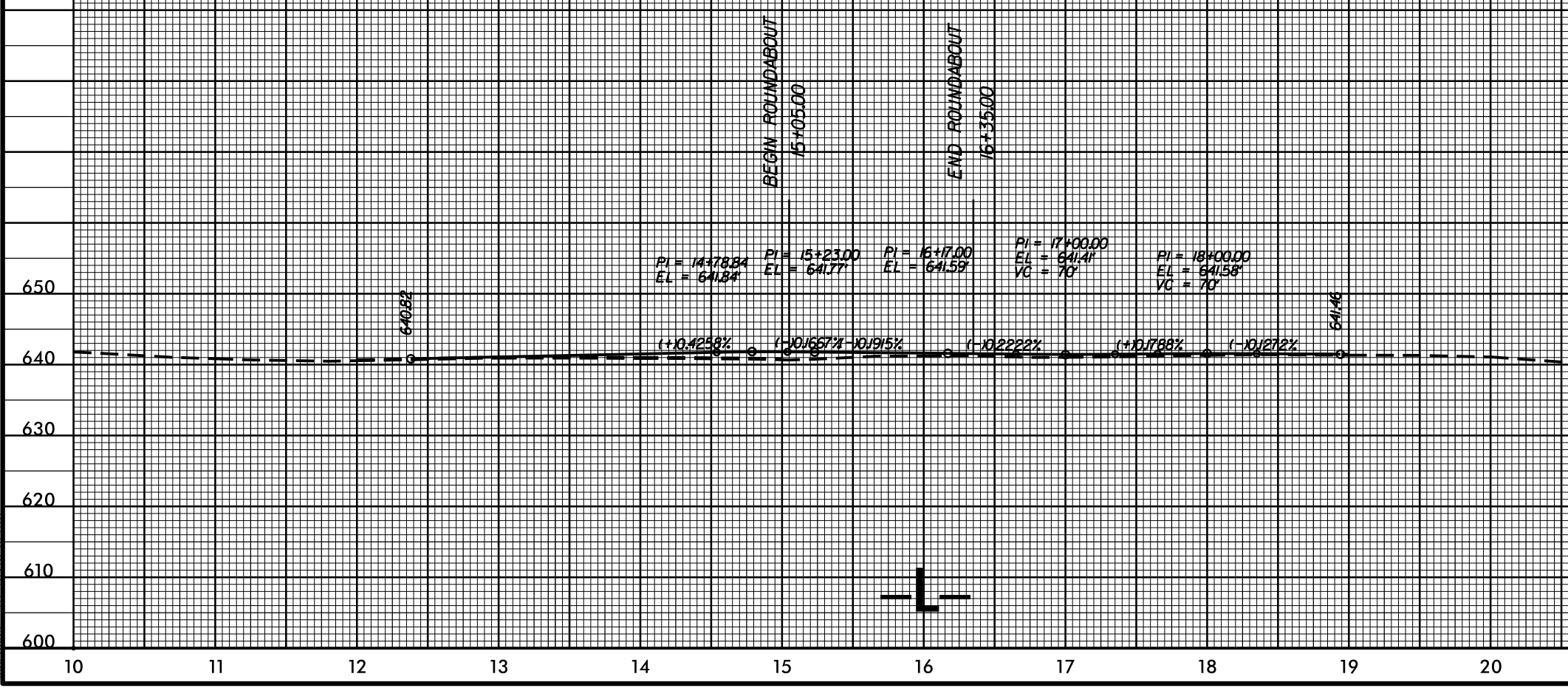

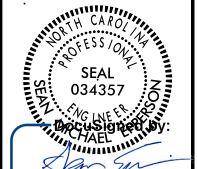

DOCUMENT NOT CONSIDERED FINAL UNLESS ALL SIGNATURES COMPLETED

15-MAR-2019 10:26 S:\DC\RDY\Uncon\W-5710K_NC 200.McWhorter_Tom Stornes.unl.plt.Y.dgn

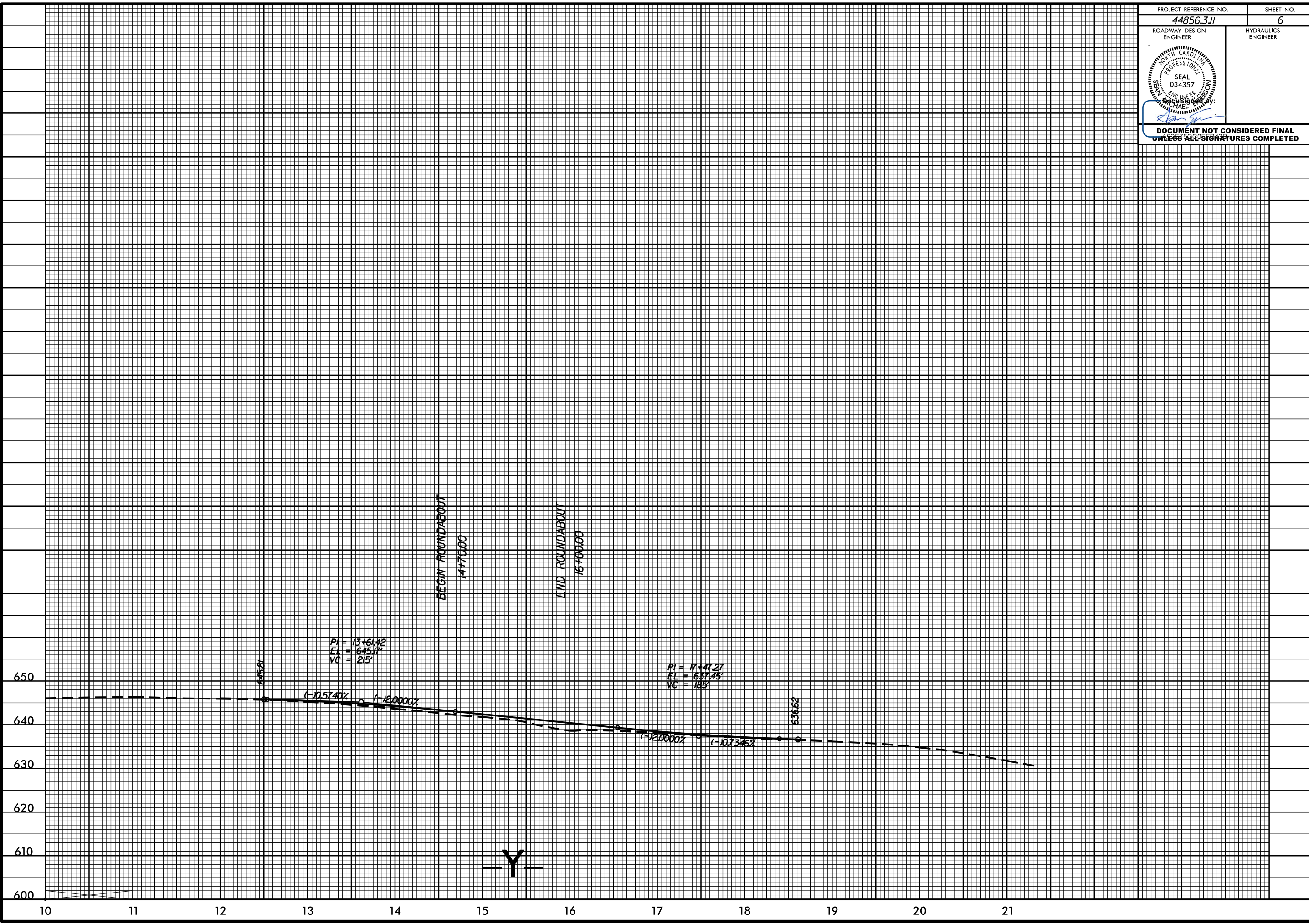

PI = 13+61.42
EL = 645.17
VC = 215'

PI = 17+47.27
EL = 637.45
VC = 185'

BEGIN ROUNDABOUT
14+70.00

END ROUNDABOUT
16+00.00

-Y-

STATE	STATE PROJECT REFERENCE NO.	SHEET NO.	TOTAL SHEETS
N.C.	44856.3.11	EC-1	
STATE PROJ. NO.	F.A. PROJ. NO.	DESCRIPTION	
44856.1.11	HSIP-0200(007)	P.E.	
44856.2.11	HSIP-0200(007)	R/W	
44856.3.11	HSIP-0200(007)	CONST.	

STATE OF NORTH CAROLINA
DIVISION OF HIGHWAYS
**PLAN FOR PROPOSED
HIGHWAY EROSION CONTROL**

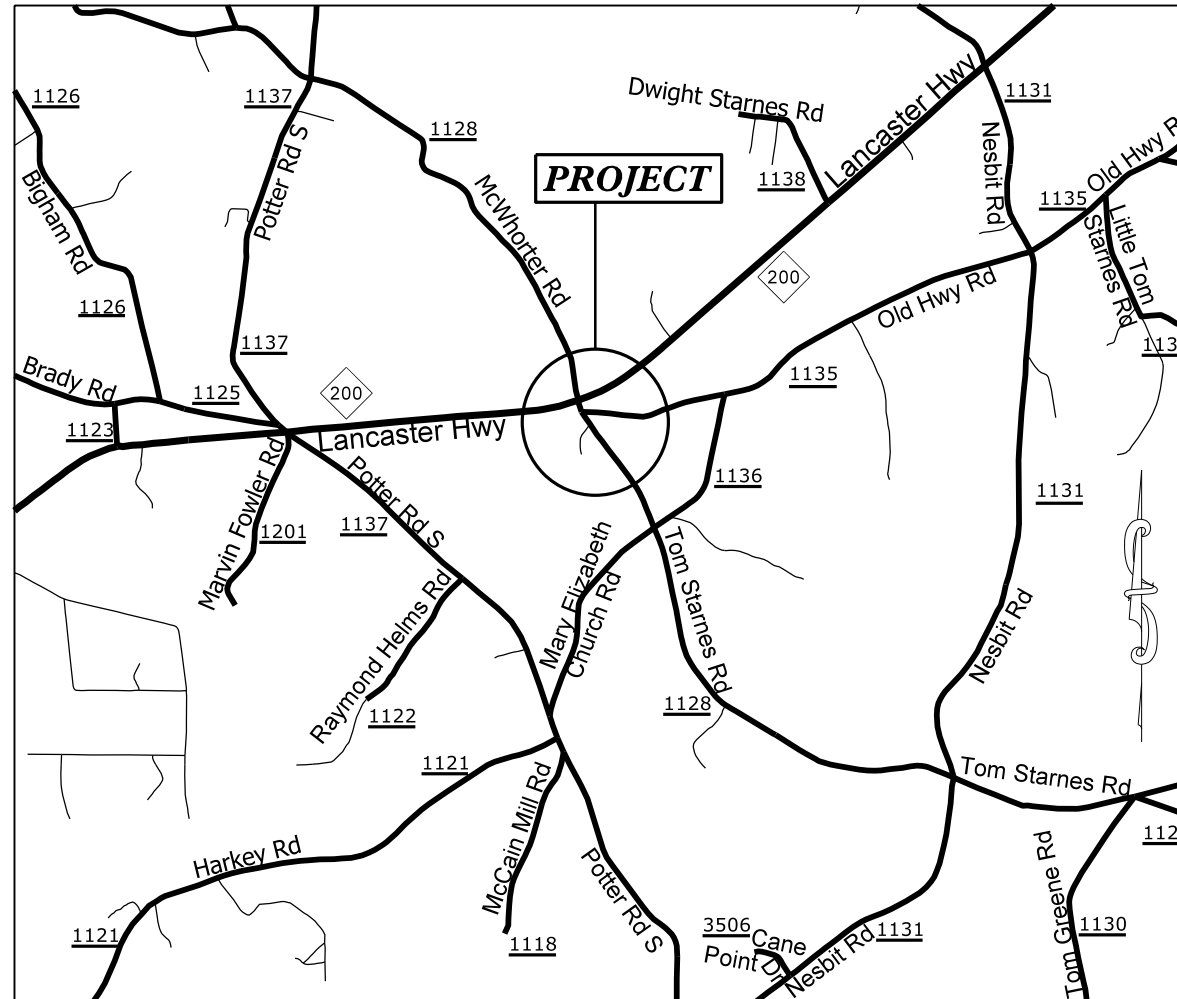

VICINITY MAP NOT TO SCALE

EROSION AND SEDIMENT CONTROL MEASURES

Std. #	Description	Symbol
1630.03	Temporary Silt Ditch	---
1630.05	Temporary Diversion	---TD---
1605.01	Temporary Silt Fence	
1606.01	Special Sediment Control Fence	---X---X---X---
1622.01	Temporary Berms and Slope Drains	T
1630.02	Silt Basin Type B	▨
1633.01	Temporary Rock Silt Check Type-A	▩
	Temporary Rock Silt Check Type-A with Matting and Polyacrylamide (PAM)	▩
1633.02	Temporary Rock Silt Check Type-B	▶
	Wattle / Coir Fiber Wattle	~
	Wattle / Coir Fiber Wattle with Polyacrylamide (PAM)	~
1634.01	Temporary Rock Sediment Dam Type-A	▭
1634.02	Temporary Rock Sediment Dam Type-B	▭
1635.01	Rock Pipe Inlet Sediment Trap Type-A	U
1635.02	Rock Pipe Inlet Sediment Trap Type-B	U
1630.04	Stilling Basin	▭
1630.06	Special Stilling Basin	▭
	Rock Inlet Sediment Trap:	
1632.01	Type A	A
1632.02	Type B	B
1632.03	Type C	C
	Skimmer Basin	▭
	Tiered Skimmer Basin	▭
	Infiltration Basin	▭

THIS PROJECT CONTAINS
EROSION CONTROL PLANS
FOR CLEARING AND
GRUBBING PHASE OF
CONSTRUCTION.

I:\M&S\2018\18-28\Roadway\44856.3.11\Station\W-5710K.NC.2018\McWhorter-Tom Starnes RAB.EC.TSH.dgn
 McWhorter-Tom Starnes RAB.EC.TSH.dgn
 JEB:cock

PROJECT: 44856.3.11 TIP: W-5710K

GRAPHIC SCALE

0

PLANS

0

PROFILE (HORIZONTAL)

0

PROFILE (VERTICAL)

ROADSIDE ENVIRONMENTAL UNIT
DIVISION OF HIGHWAYS
STATE OF NORTH CAROLINA

THESE EROSION AND SEDIMENT CONTROL PLANS COMPLY
WITH THE REGULATIONS SET FORTH BY THE
NCG-010000 GENERAL CONSTRUCTION PERMIT EFFECTIVE AUGUST 3, 2011
ISSUED BY THE NORTH CAROLINA DEPARTMENT OF ENVIRONMENT AND
NATURAL RESOURCES DIVISION OF WATER QUALITY.

Prepared In the Office of:
DDC UNIT DIVISION 10
DEPARTMENT OF TRANSPORTATION
DIVISION OF HIGHWAYS

2018 STANDARD SPECIFICATIONS

Designed by:

CHAD BURRIS **4159**

NAME LEVEL III CERTIFICATION NO.

Roadway Standard Drawings

The following roadway english standards as appear in "Roadway Standard Drawings"- Roadway Design Unit - N. C. Department of Transportation - Raleigh, N. C., dated January 2018 and the latest revision thereto are applicable to this project and by reference hereby are considered a part of these plans.

1604.01 Railroad Erosion Control Detail	1632.01 Rock Inlet Sediment Trap Type A
1605.01 Temporary Silt Fence	1632.02 Rock Inlet Sediment Trap Type J
1606.01 Special Sediment Control Fence	1632.03 Rock Inlet Sediment Trap Type C
1607.01 Gravel Construction Entrance	1633.01 Temporary Rock Silt Check Type A
1622.01 Temporary Berms and Slope Drains	1633.02 Temporary Rock Silt Check Type J
1630.01 Riser Basin	1634.01 Temporary Rock Sediment Dam Type A
1630.02 Silt Basin Type J	1634.02 Temporary Rock Sediment Dam Type J
1630.03 Temporary Silt Ditch	1635.01 Rock Pipe Inlet Sediment Trap Type A
1630.04 Stilling Basin	1635.02 Rock Pipe Inlet Sediment Trap Type J
1630.05 Temporary Diversion	1640.01 Coir Fiber Jaffle
1630.06 Special Stilling Basin	1645.01 Temporary Stream Crossing
1631.01 Matting Installation	

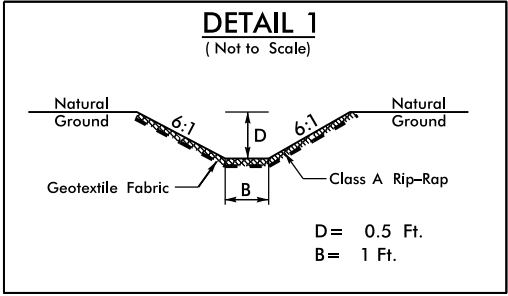
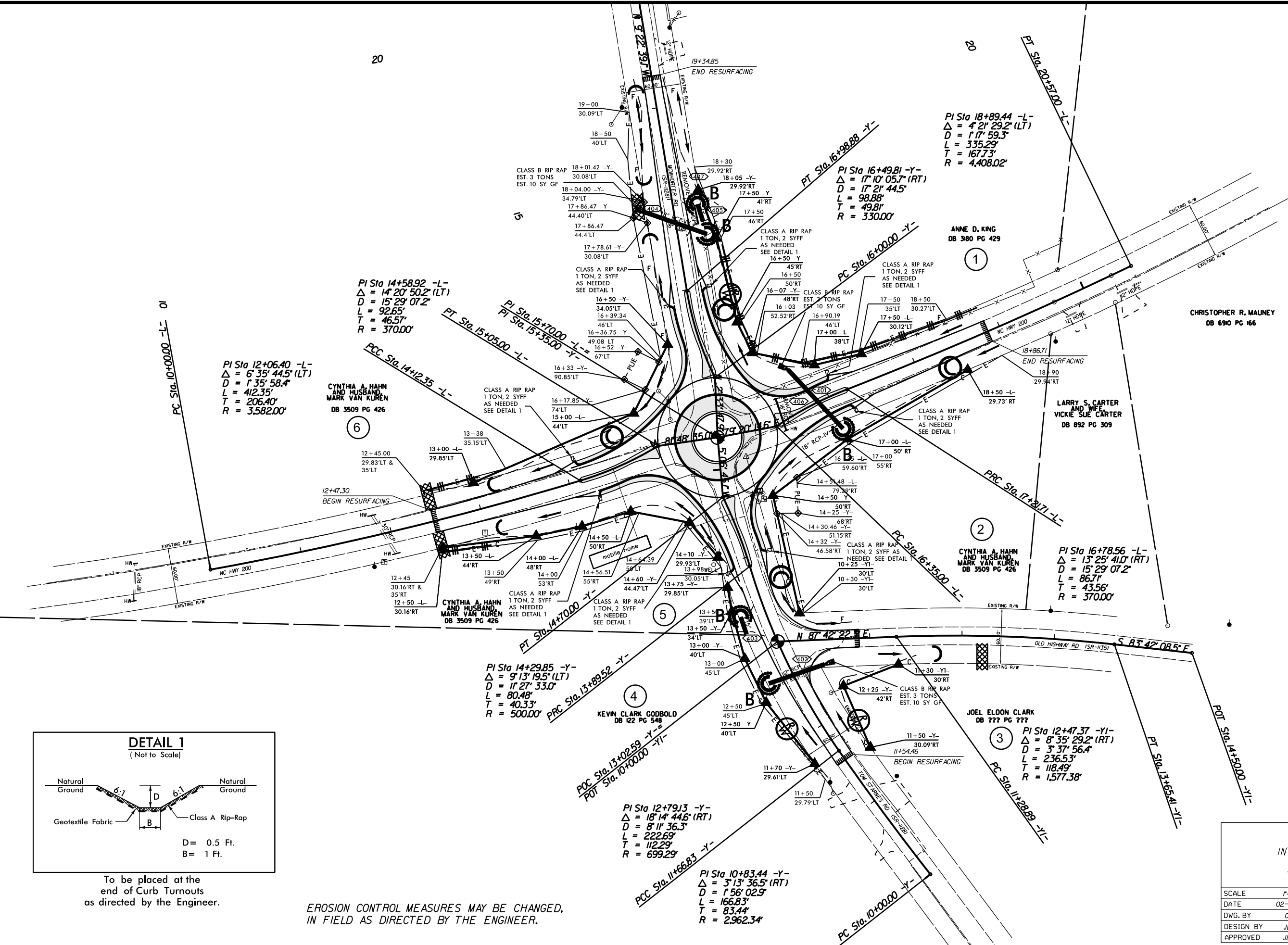
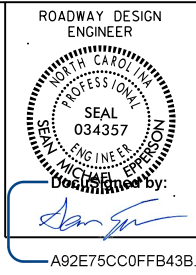

To be placed at the end of Curb Turnouts as directed by the Engineer.

EROSION CONTROL MEASURES MAY BE CHANGED, IN FIELD AS DIRECTED BY THE ENGINEER.

ROUNDABOUT AT THE INTERSECTION OF NC 200 AND McWHORTER RD.(SR-1128) / TOM STARNES RD.(SR-1128)

SCALE	1"=50'	REVISIONS
DATE	02-2019	
DWG. BY	CEB	
DESIGN BY	JDH	
APPROVED	JDH	

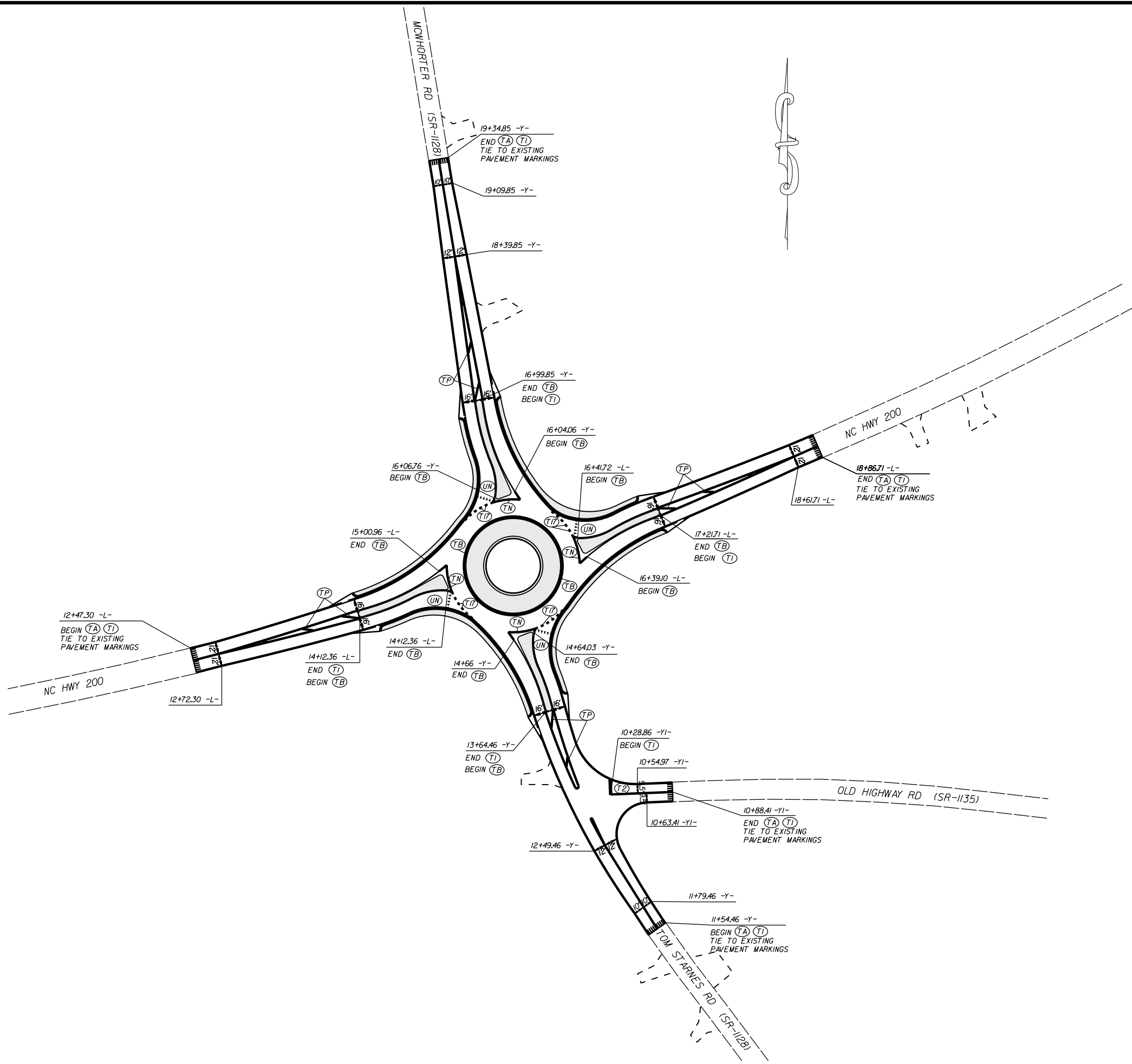
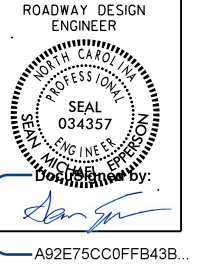

PAVEMENT MARKING SCHEDULE

PAVEMENT MARKING LINES

- | | |
|---|--|
| TA - WHITE EDGELINE (4',.90 MIL) | TU - WHITE DIAGONAL (12',.90 MIL) |
| TB - YELLOW EDGELINE (4',.90 MIL) | TV - YELLOW DIAGONAL (12',.90 MIL) |
| TC - 10FT. WHITE SKIP (4',.90 MIL) | TI - WHITE LINE, RR X (16',.90 MIL) |
| TD - 3FT.-9FT./SP WHITE MINISKIP (4',.90 MIL) | T2 - WHITE STOPBAR (24',.90 MIL) |
| TE - WHITE SOLID LANE LINE (4',.90 MIL) | T3 - WHITE CROSSWALK LINE (24',.90 MIL) |
| TF - 10FT. YELLOW SKIP (4',.90 MIL) | T4 - WHITE RUMBLE STRIP (4',.240 MIL) |
| TH - YELLOW SINGLE CENTER (4',.90 MIL) | T5 - YELLOW RUMBLE STRIP (4',.240 MIL) |
| TJ - YELLOW DOUBLE CENTER (4',.90 MIL) | T6 - WHITE EDGELINE (6',.90 MIL) |
| TK - 10FT. WHITE SKIP (6',.90 MIL) | T7 - YELLOW EDGELINE (6',.90 MIL) |
| TL - WHITE SOLID LANE LINE (6',.90 MIL) | T8 - 2FT.-6FT./SP WHITE MINISKIP (4',.90 MIL) |
| TM - 10FT. YELLOW SKIP (6',.90 MIL) | T9 - 2FT.-6FT./SP YELLOW MINISKIP (4',.90 MIL) |
| TN - WHITE GORELINE (8',.90 MIL) | T10 - 3FT.-3FT./SP WHITE MINISKIP (12',.90 MIL) |
| TO - WHITE DIAGONAL (8',.90 MIL) | T11 - 2FT.-6FT./SP WHITE MINISKIP (6',.90 MIL) |
| TP - YELLOW DIAGONAL (8',.90 MIL) | T12 - 2FT.-6FT./SP YELLOW MINISKIP (6',.90 MIL) |
| TQ - WHITE CROSSWALK LINE (8',.90 MIL) | T13 - 3FT.-9FT./SP WHITE MINISKIP (8',.90 MIL) |
| TR - WHITE SOLID LANE LINE (8',.90 MIL) | T14 - 3FT.-9FT./SP WHITE MINISKIP (12',.90 MIL) |
| TS - WHITE GORELINE (12',.90 MIL) | T15 - YELLOW SINGLE CENTER (6',.90 MIL) |
| TT - WHITE SOLID LANE LINE (12',.90 MIL) | T16 - YELLOW DOUBLE CENTER (6',.90 MIL) |
| | T17 - 3FT.-3FT./SP WHITE MINISKIP ENTRANCE LINE (8',.90 MIL) |

PAVEMENT MARKING SYMBOLS

- | | |
|--|--|
| UA - LEFT TURN ARROW (90 MIL) | UU - FISH-HOOK STRAIGHT ARROW (90 MIL) |
| UB - RIGHT TURN ARROW (90 MIL) | UV - FISH-HOOK LEFT/STRAIGHT ARROW (90 MIL) |
| UC - STRAIGHT ARROW (90 MIL) | UW - FISH-HOOK RIGHT/STRAIGHT ARROW (90 MIL) |
| UD - COMBO. LEFT/STRAIGHT ARROW (90 MIL) | UX - FISH-HOOK LEFT/RIGHT ARROW (90 MIL) |
| UE - COMBO. RIGHT/STRAIGHT ARROW (90 MIL) | UY - FISH-HOOK LEFT/RIGHT/STRAIGHT ARROW (90 MIL) |
| UF - COMBO. LEFT/RIGHT ARROW (90 MIL) | UZ - FISH-HOOK W/CIRCLE STRAIGHT ARROW (90 MIL) |
| UG - COMBO. LEFT/RIGHT/STRAIGHT ARROW (90 MIL) | |
| UH - HANDICAP PARKING (90 MIL) | WA - FISH-HOOK W/CIRCLE LEFT ARROW (90 MIL) |
| UI - ALPHANUMERIC CHAR. (90 MIL) | WB - FISH-HOOK W/CIRCLE LEFT/STRAIGHT ARROW (90 MIL) |
| UJ - BICYCLE SYMBOL (90 MIL) | WC - FISH-HOOK W/CIRCLE LEFT/RIGHT/STRAIGHT ARROW (90 MIL) |
| UK - BICYCLE STRAIGHT ARROW (90 MIL) | |
| UL - BICYCLE CHAR. (90 MIL) | MA - PERMANENT RAISED MARKER (YELLOW & YELLOW) |
| UM - 12' YIELD LINE TRIANGLE (90 MIL) | MB - PERMANENT RAISED MARKER (CRYSTAL & RED) |
| UN - 24' YIELD LINE TRIANGLE (90 MIL) | MC - PERMANENT RAISED MARKER (YELLOW & RED) |
| UO - BICYCLE LEFT ARROW (90 MIL) | MD - PERMANENT RAISED MARKER (YELLOW) |
| UP - MERGE ARROW (90 MIL) | ME - SNOWFLOWABLE MARKER (YELLOW & YELLOW) |
| UQ - RAMP ARROW SYMBOL (90 MIL) | MF - SNOWFLOWABLE MARKER (CRYSTAL & RED) |
| UR - SHARROW (90 MIL) | MG - SNOWFLOWABLE MARKER (YELLOW & RED) |
| US - BICYCLE LOOP DETECTOR (90 MIL) | ML - PERMANENT RAISED MARKER (CRYSTAL & CRYSTAL) |
| UT - U-TURN ARROW (90 MIL) | MO - SNOWFLOWABLE MARKER (CRYSTAL & CRYSTAL) |

ROUNDABOUT AT THE INTERSECTION OF NC 200 AND McWHORTER RD (SR-1128)/ TOM STARNES RD.(SR-1128)

SCALE	1"=50'		REVISIONS
DATE	2-2019		
DWG. BY	JCB		
DESIGN BY	JDH		
APPROVED	JDH		

PROJECT NO.	SHEET NO.
44856.3,II	TCP-1
F.A. PROJECT NO. HSP-02001007)	

ROADWAY DESIGN
ENGINEER

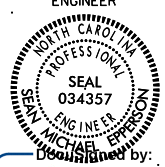

Designed by:
Salina Blalock

A92E75CC0FFB43B...

OFFSITE DETOUR

OFFSITE DETOUR TO BE INSTALLED AND MAINTAINED BY NCDOT.
THE CONTRACTOR IS RESPONSIBLE FOR THE BARRACADES ON THE PROJECT. SEE SHEET TCP-2

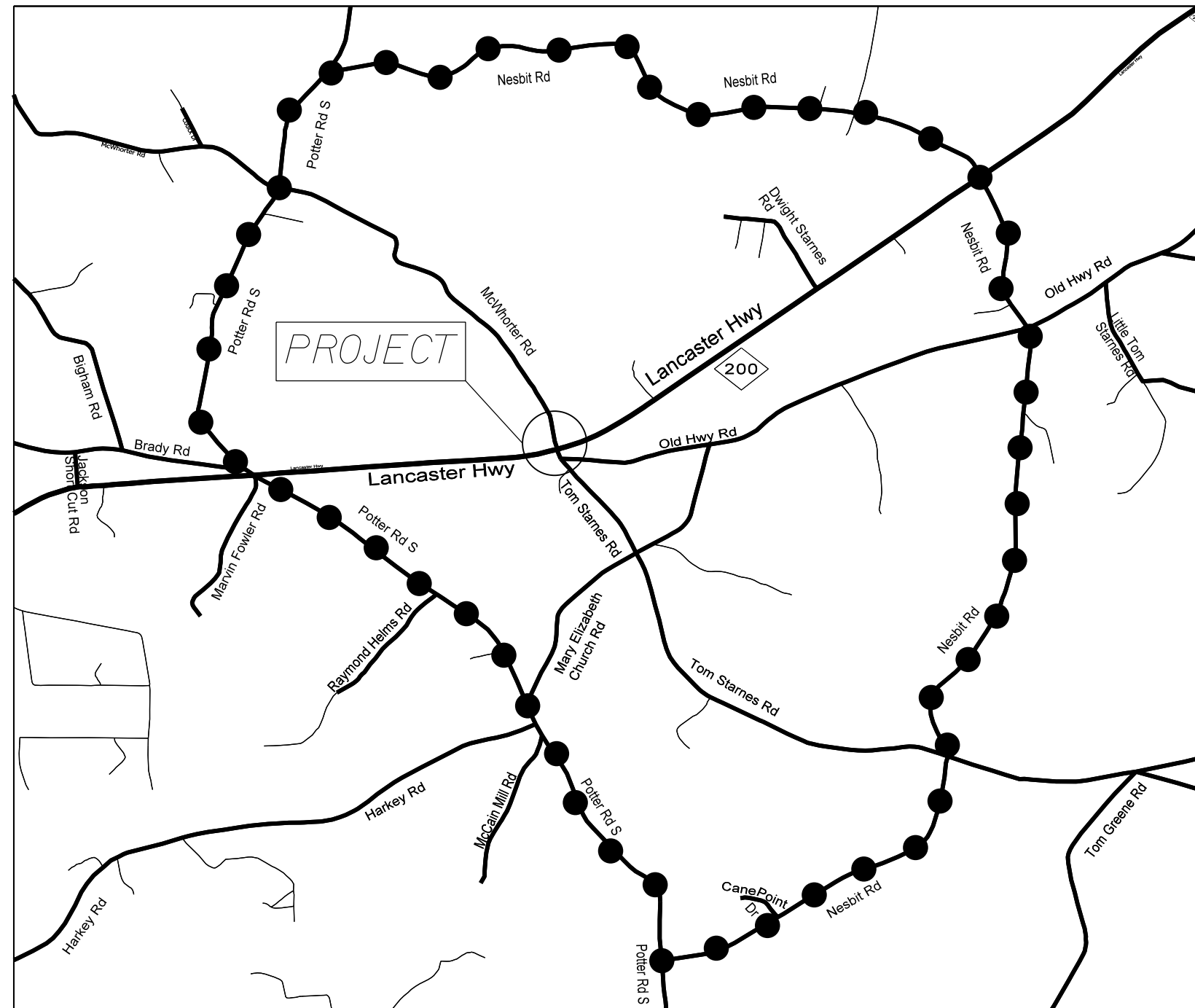

NOTE: CONTRACTOR SHALL CONTACT
SALINA BLALOCK AT 704-244-8270
TWO WEEKS PRIOR TO ROAD CLOSURE.

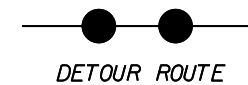

ROUNDABOUT AT THE
INTERSECTION OF NC 200 AND
McWHORTER RD.(SR-1128)/
TOM STARNES RD.(SR-1128)

SCALE	1"=50'
DATE	2-2019
DWG. BY	JCB
DESIGN BY	JDH
APPROVED	JDH



REVISIONS	

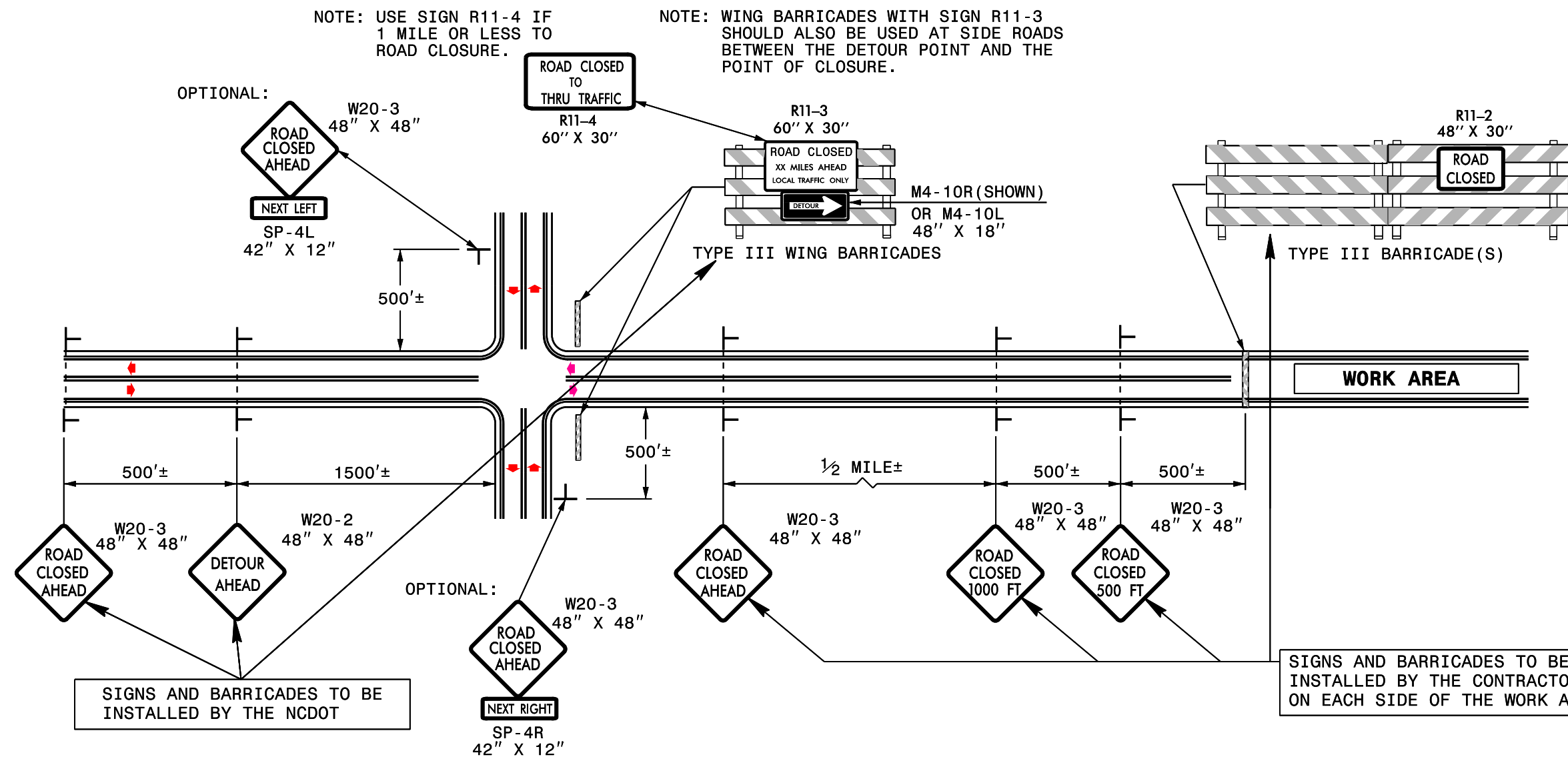
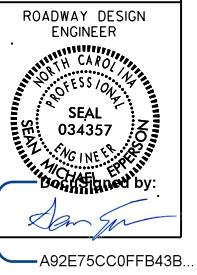

NOTE: USE SIGN R11-4 IF 1 MILE OR LESS TO ROAD CLOSURE.

NOTE: WING BARRICADES WITH SIGN R11-3 SHOULD ALSO BE USED AT SIDE ROADS BETWEEN THE DETOUR POINT AND THE POINT OF CLOSURE.

SIGNS AND BARRICADES TO BE INSTALLED BY THE NCDOT

SIGNS AND BARRICADES TO BE INSTALLED BY THE CONTRACTOR ON EACH SIDE OF THE WORK AREA.

GENERAL NOTES

- 1-IF NECESSARY USE THIS STD. FOR TWO-LANE, TWO-WAY, AND MULTILANE DIVIDED AND UNDIVIDED ROADWAYS.
- 2-INSTALLATION OF DETOUR ROUTING PANELS, TEMPORARY ROUTE MARKERS, DESTINATION SIGNS, AND ANY NECESSARY MODIFICATIONS TO EXISTING OR PROPOSED REGULATORY OR WARNING SIGNS WILL BE MADE BY NCDOT FORCES UNLESS OTHERWISE DESIGNATED IN THE PLANS. PROVIDE A MINIMUM 21 CALENDAR DAY NOTICE TO STATE FORCES BEFORE A ROADWAY IS CLOSED TO TRAFFIC SUCH THAT THE NECESSARY PROVISIONS CAN BE MADE TO INSTALL DETOUR ROUTE SIGNS, INFORM LOCAL EMERGENCY AND LAW ENFORCEMENT PERSONNEL, SCHOOLS, OR ANY OTHER PARTIES AFFECTED BY THE ROAD CLOSURE.
- 3-INSTALL SIGNS BEFORE THE BARRICADES WHEN CLOSING THE ROADWAY TO TRAFFIC. REMOVE BARRICADES BEFORE SIGNS WHEN OPENING THE ROADWAY TO TRAFFIC. INSTALL/REMOVE SIGNS AND BARRICADES WITHIN THE SAME CALENDAR DAY.
- 4-USE ADDITIONAL TYPE III BARRICADES IN STAGGERED LOCATIONS SUPPLEMENTED WITH SIGN R11-4 "ROAD CLOSED TO THRU TRAFFIC" IN THE EVENT THAT TRAFFIC MUST BE MAINTAINED BEYOND THE DETOUR POINT.
- 5-DO NOT DISPLAY FRACTIONS OR DECIMALS ON SIGN R11-3 "ROAD CLOSED XX MILES AHEAD".
- 6-POSITION WING BARRICADES ON THE SHOULDERS AND SLOPE THE STRIPES DOWNWARD IN THE DIRECTION TOWARD WHICH TRAFFIC MUST TURN IN DETOURING.
- 7-USE PORTABLE SIGNS IF ROAD CLOSURE IS TO BE IMPLEMENTED FOR LESS THAN ONE DAY OR FOR EMERGENCIES.

LEGEND

┆ STATIONARY SIGN

◄ DIRECTION OF TRAFFIC FLOW

ROUNDABOUT AT THE INTERSECTION OF NC 200 AND McWHORTER RD.(SR-1128)/ TOM STARNES RD.(SR-1128)

SCALE	r=50'	REVISIONS
DATE	2-2019	
DWG. BY	JCB	
DESIGN BY	JDH	
APPROVED	JDH	

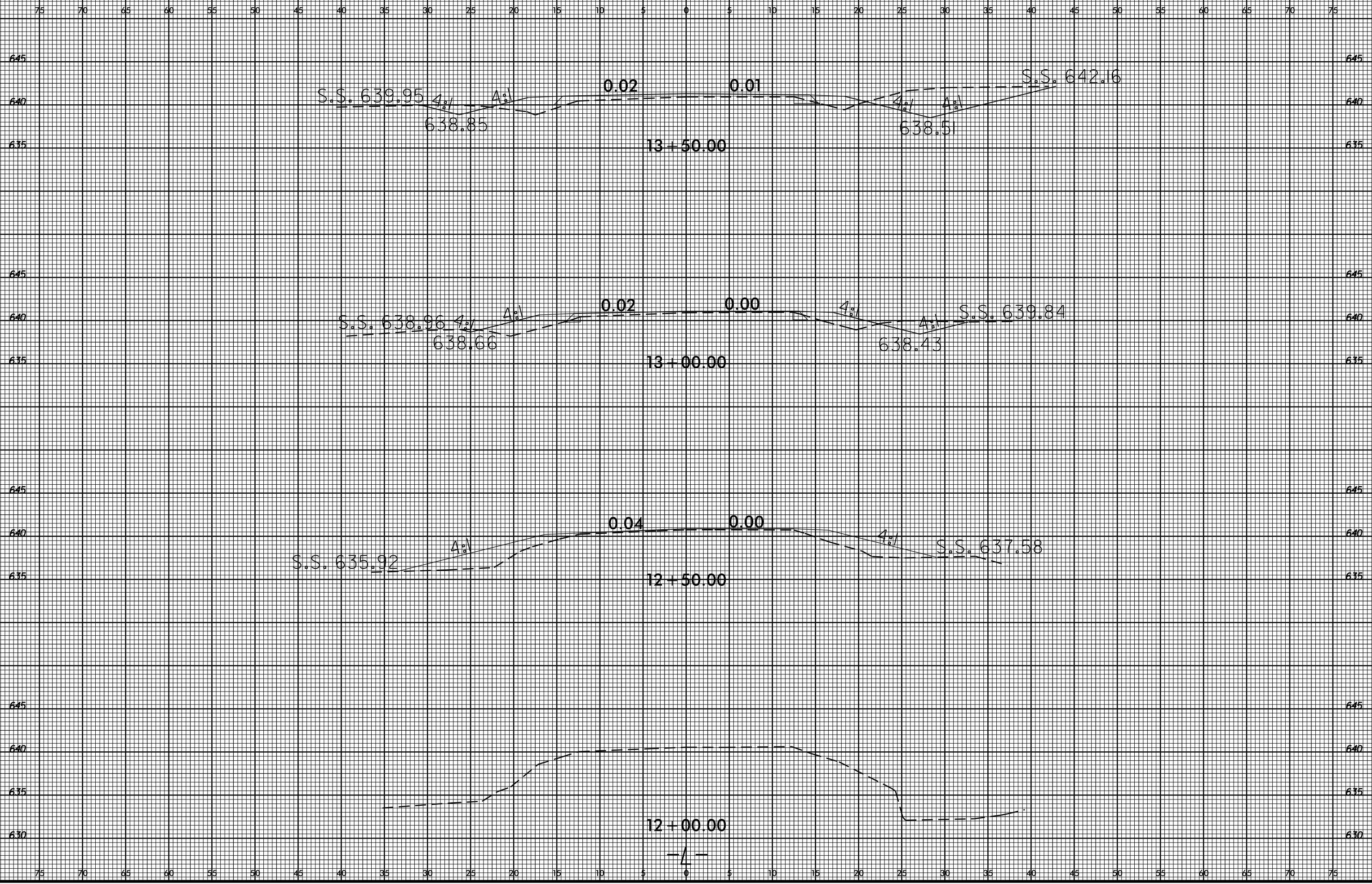

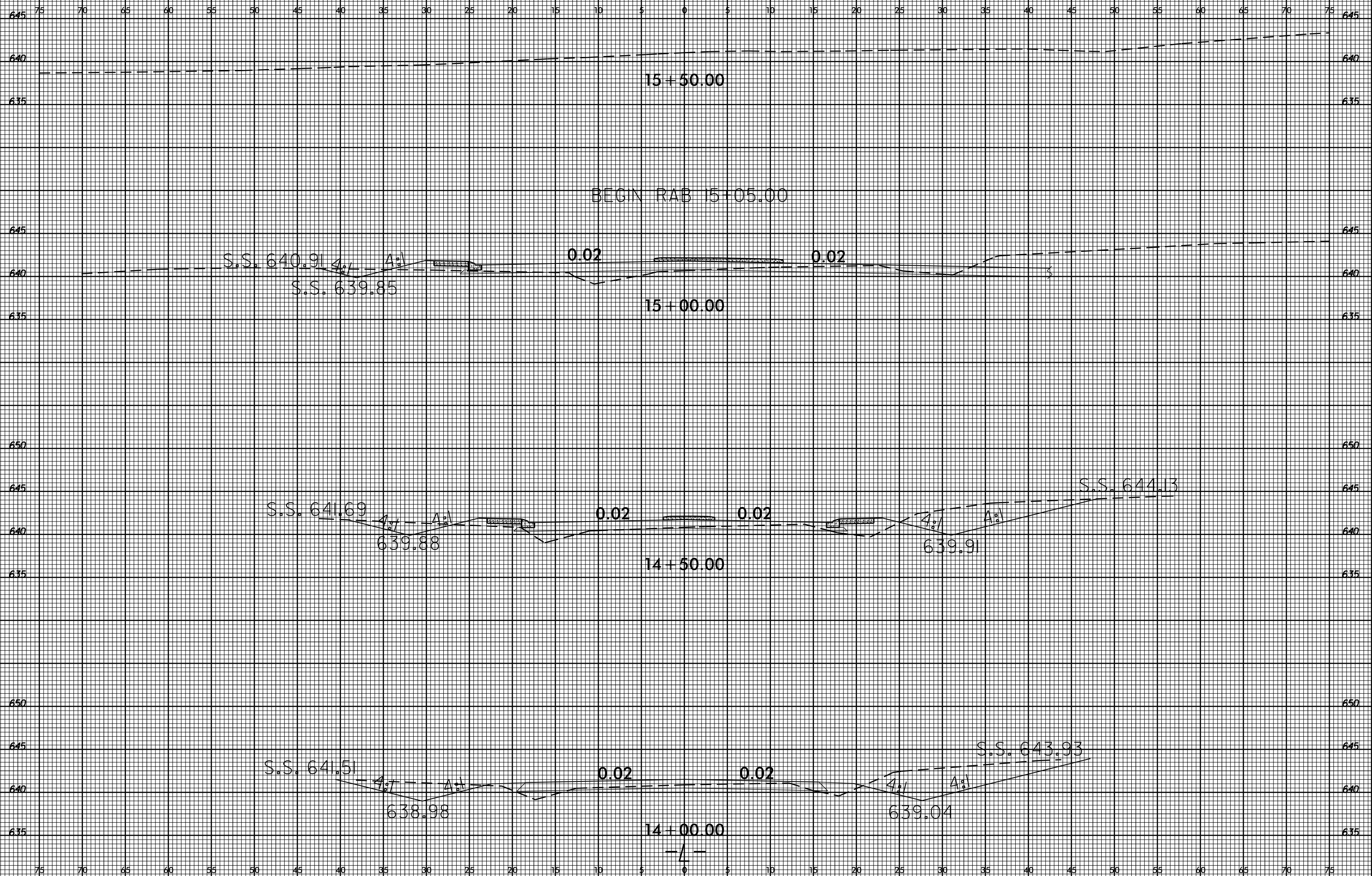

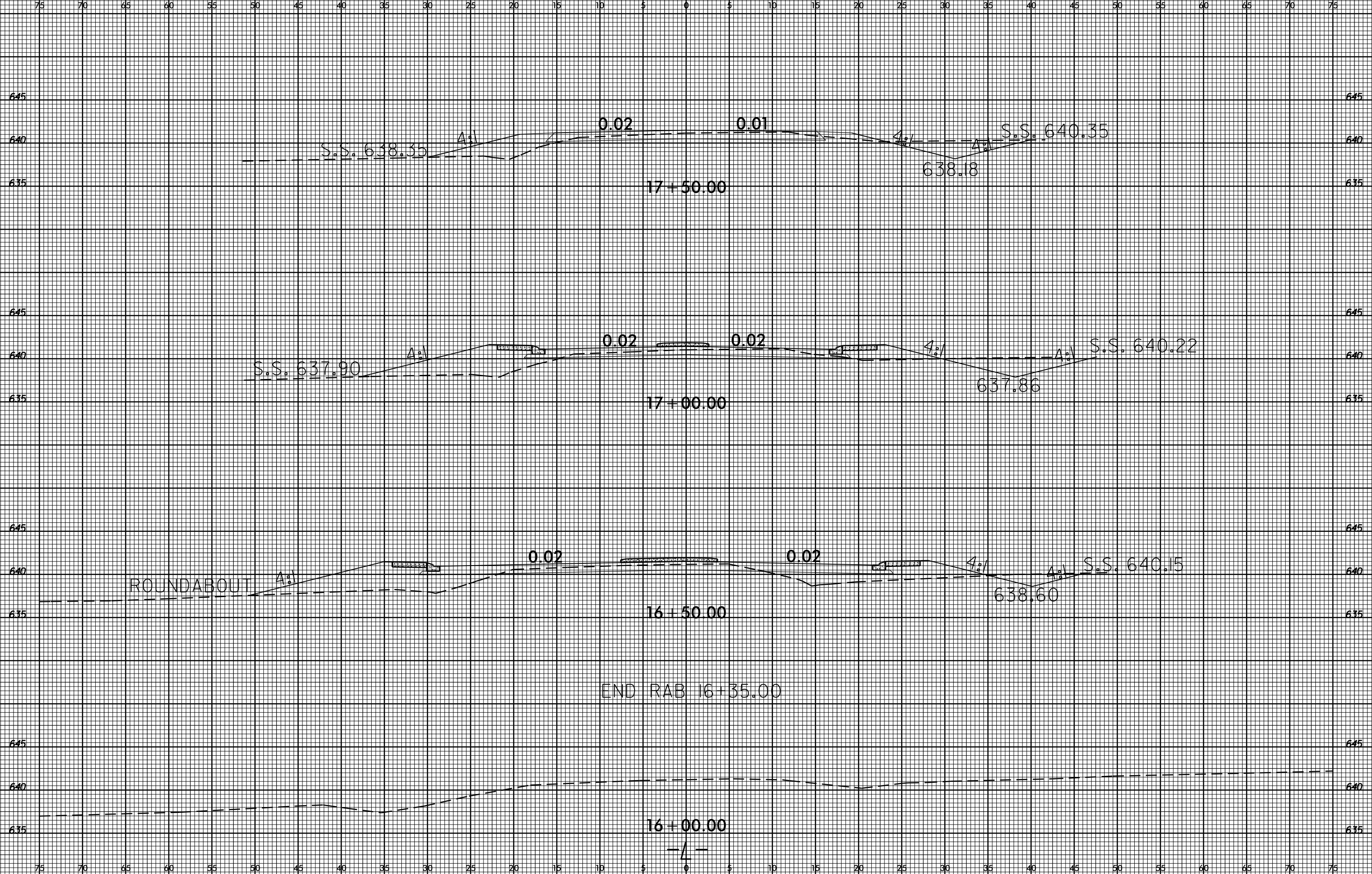

I5-MAR-2018 10:40
 S:\DOD\RDY\Urban\W-5710K_NC 2002\Starnes RAB\XSC\NC 2002\McWhorter_Tom Starnes.unl.xpl.L.dgn
 icbrooks

75 70 65 60 55 50 45 40 35 30 25 20 15 10 5 0 5 10 15 20 25 30 35 40 45 50 55 60 65 70 75

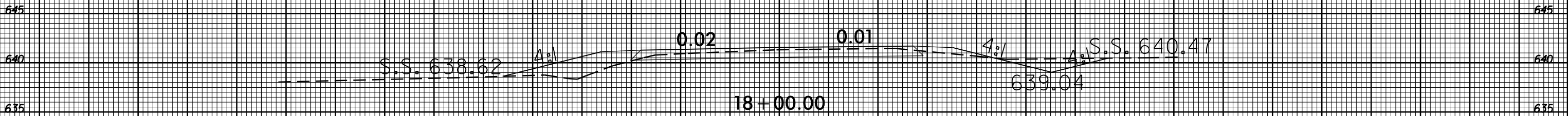
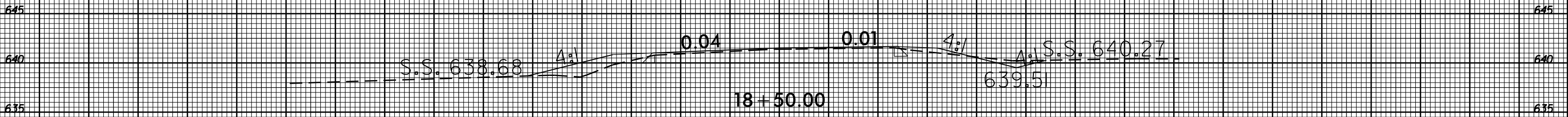
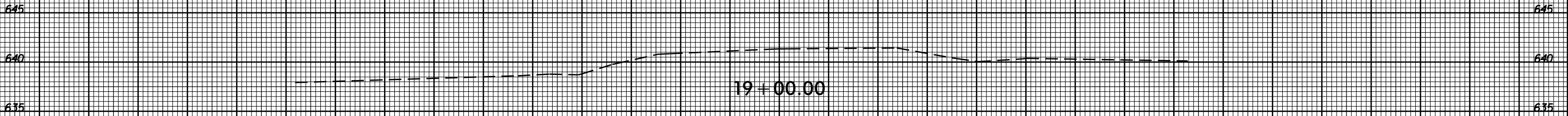
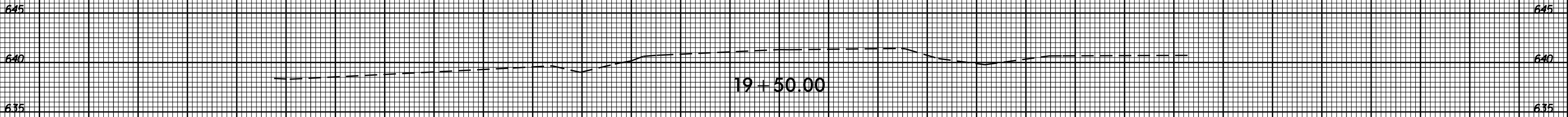

75 70 65 60 55 50 45 40 35 30 25 20 15 10 5 0 5 10 15 20 25 30 35 40 45 50 55 60 65 70 75

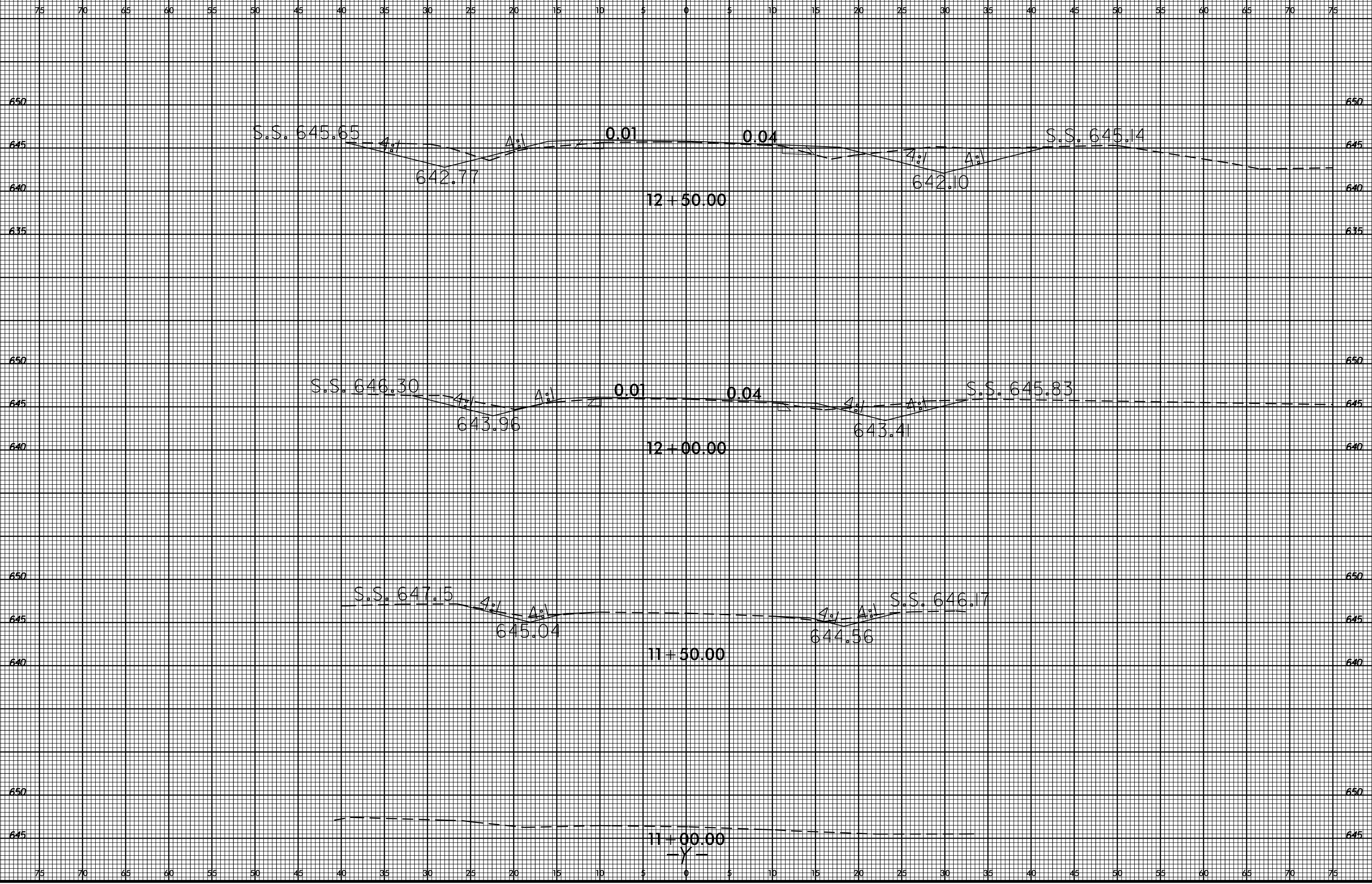

I5-MAR-2018 10:42
 S:\D\C\RD\Y\Urin\m\W-5710K_NC_200.McWhorter_Tom.Starnes.unl.xpl_Y.dgn
 c:\brooks

75 70 65 60 55 50 45 40 35 30 25 20 15 10 5 0 5 10 15 20 25 30 35 40 45 50 55 60 65 70 75

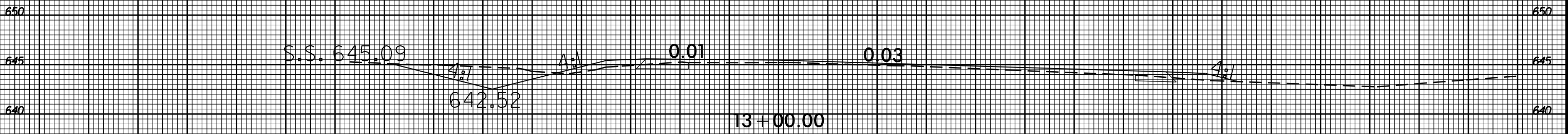
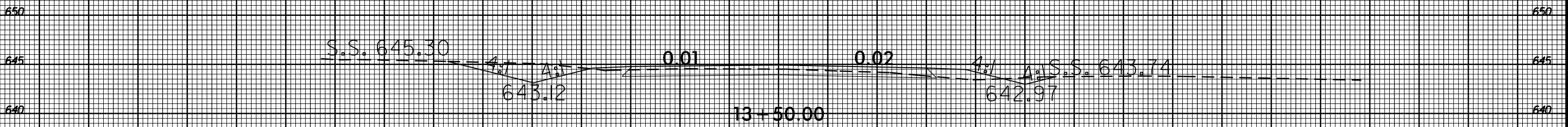
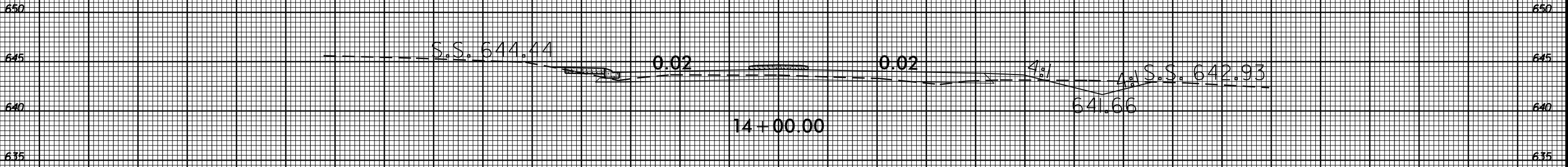

--Y--

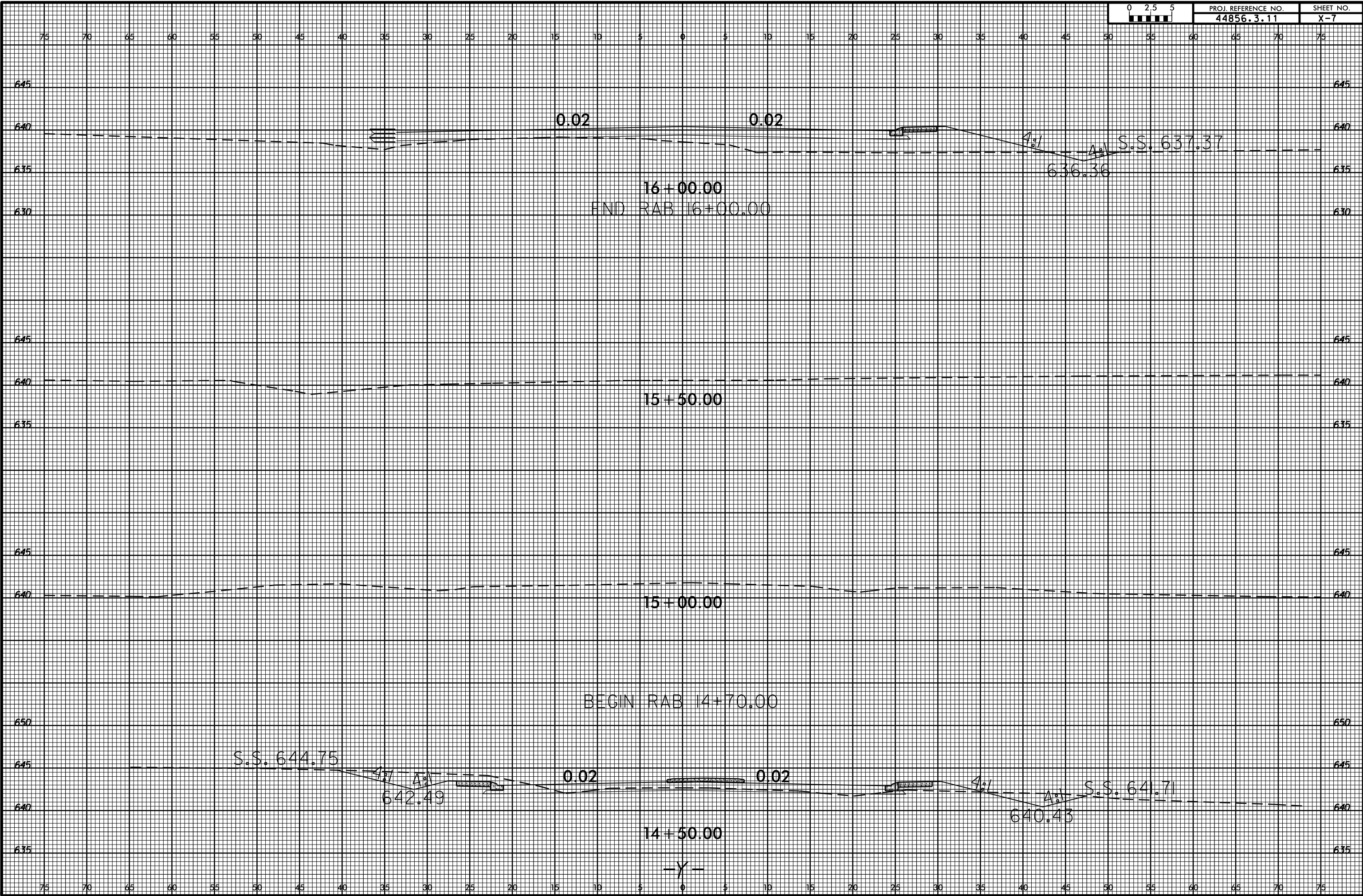

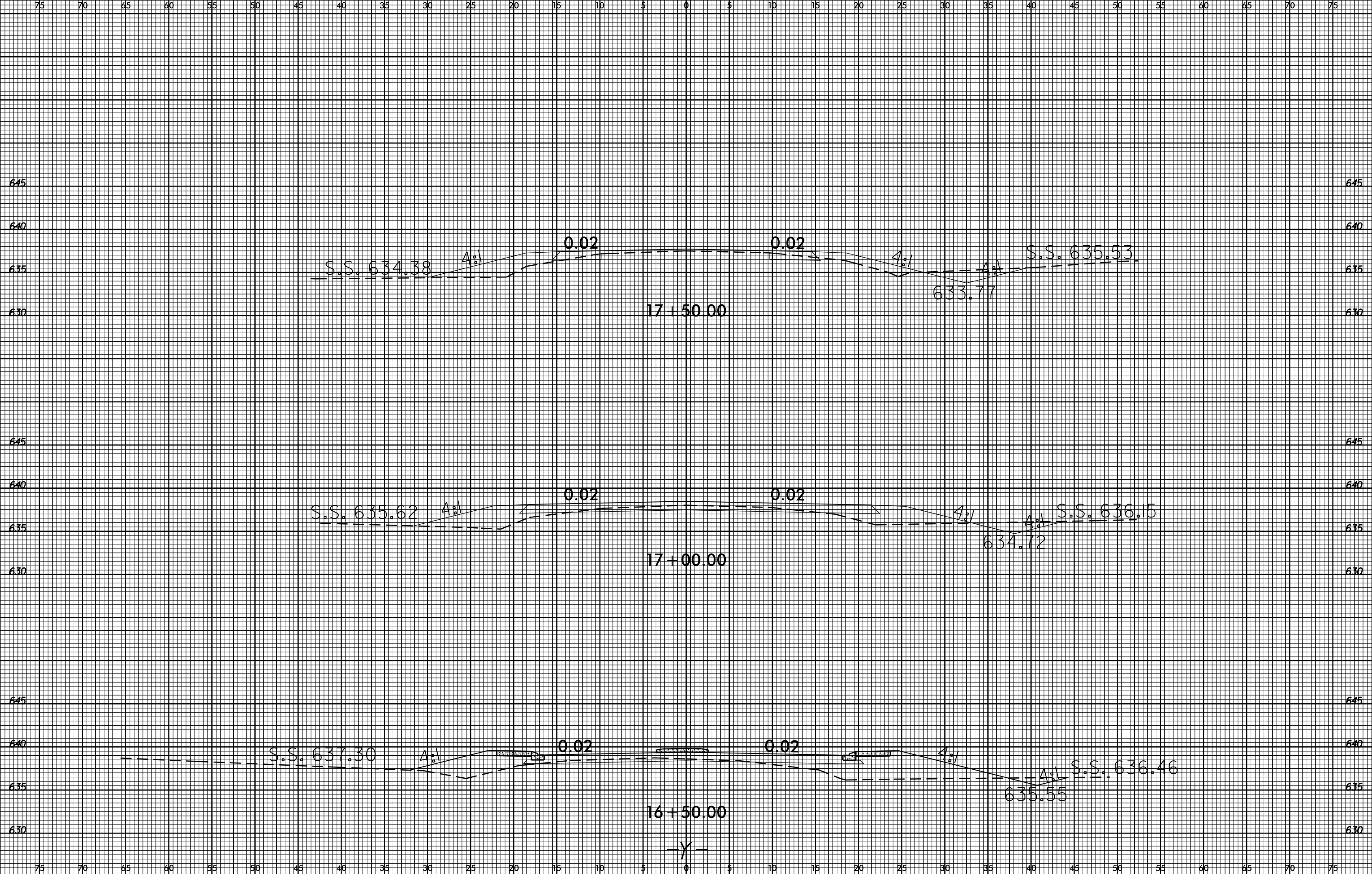

75 70 65 60 55 50 45 40 35 30 25 20 15 10 5 0 5 10 15 20 25 30 35 40 45 50 55 60 65 70 75

640 640

635 635

630 630

19+50.00

640 640

635 635

630 630

19+00.00

S.S. 635.34

4:1

0.02

0.02

4:1

S.S. 635.67

640 640

635 635

630 630

18+50.00

S.S. 633.93

4:1

0.02

0.02

4:1

S.S. 635.82

640 640

635 635

630 630

18+00.00

S.S. 633.23

4:1

0.02

0.02

4:1

4:1

S.S. 636.02

634.70

--Y--

75 70 65 60 55 50 45 40 35 30 25 20 15 10 5 0 5 10 15 20 25 30 35 40 45 50 55 60 65 70 75

I:\MAR-2018_1044
S:\DOD\RDY\Urgen\W-57106_NC 200.McWhorter_Tom.Starnes\RAB\XSC\NC 200.McWhorter_Tom.Starnes.unl.xpl_Y.dgn
cbrooks

